

Dealer's Manual

| | | |
|-------------------------------|-------------|----------|
| ROAD | MTB | Trekking |
| City Touring/ Comfort Bike | URBAN SPORT | E-BIKE |

SHIMANO STEPS E6100 Series

SC-E6100
EW-EN100
SW-E6010-L
SW-M8050-L
SW-E6010-R
SW-M8050-R
RD-M8050
MU-UR500
FC-E6100
FC-E8000
FC-E8050
FC-M8050
SM-CRE61
DU-E6100
DU-E6110
SM-DUE10
SM-DUE11
SM-DUE61-T
SM-DUE61-TC
SM-DUE61-C
SM-DUE61-CC

BT-E6000
BT-E6001
BT-E6010
BT-E8010
BT-E8014
BT-E8020
BM-E6000
BM-E6010
BM-E8010
BM-E8020
TL-FC39
TL-FC36
TL-LR15
RT-EM800
RT-EM900

CONTENTS

| | |
|---|-----------|
| CONTENTS | 2 |
| IMPORTANT NOTICE | 6 |
| TO ENSURE SAFETY | 7 |
| LIST OF TOOLS TO BE USED | 12 |
| INSTALLING ELECTRICAL PARTS | 14 |
| Names of parts | 14 |
| • Rear carrier mount type | 14 |
| • Down tube mount type | 15 |
| • Built-in type | 16 |
| Overall Wiring Diagram..... | 18 |
| Specifications..... | 19 |
| Handling Electric Wires..... | 19 |
| • Connecting the electric wire..... | 20 |
| • Disconnecting the electric wire | 21 |
| Installing the Cycle Computer/Junction (A) | 22 |
| • SC-E6100..... | 22 |
| • EW-EN100..... | 27 |
| Installing the Switch Unit (SW-E6010)..... | 29 |
| Installing the Switch Unit (SW-M8050) | 30 |
| • Connecting the electric wire..... | 31 |
| Wiring around the Cockpit (SC-E6100) | 33 |
| • Example: Routing the electric wire | 34 |
| Wiring around the Cockpit (EW-EN100) | 37 |
| • Example: Routing the electric wire | 38 |
| Installing the Battery Mount..... | 40 |
| • BM-E6000 | 40 |
| • BM-E6010 | 44 |
| • BM-E8010 | 49 |
| • BM-E8020 | 52 |

- Installing the Speed Sensor and Magnet Unit 57**
 - SM-DUE10 57
 - SM-DUE11 59

INSTALLING THE DRIVE UNIT AND PERIPHERAL PARTS 61

- Installing the Drive Unit 61**

- Connecting the Power Cord 64**
 - Connection method 64
 - Removal method 65

- Connecting Cockpit Peripheral Parts and Electronic Gear Shifting Components 66**

- Connecting the Speed Sensor 67**

- Connecting the Light Cables 68**

- Installing the Drive Unit Cover..... 69**
 - SHIMANO drive unit cover only..... 69
 - Used with drive unit cover from other company 71

- Installing the Front Chainring and Crank Arms 73**

- Installing the Arm Covers..... 78**

- Measuring and Adjusting the Chain Tension 80**
 - Manual adjustment 80

HANDLING THE BATTERY 81

- Installing the Battery 81**
 - Rear carrier mount type..... 82
 - Down tube mount type 83
 - Built-in type 84

- Removing the Battery..... 84**
 - Rear carrier mount type..... 85
 - Down tube mount type 85
 - Built-in type 86

- Charging the Battery 88**
 - Deep sleep mode..... 88
 - NOTICE 88
 - Charging time..... 89

- Charging the battery removed from the bicycle..... 90
- Charging the battery attached to the bicycle 92
- Battery charger LED indication..... 93
- Battery LED indication 93

OPERATION AND SETTING 96

Turning Power ON/OFF 96

- Operating power from the cycle computer 96
- Operating power from the battery..... 97
- Screen display when power is ON 98

Basic Operation 99

- Cycle computer and switch unit 99
- Junction (A) (EW-EN100)..... 101

Light ON/OFF 101

- SC-E6100..... 102
- EW-EN100..... 102

Basic Status Display 103

- SC-E6100..... 103
- EW-EN100..... 104
- Battery level indicator 105

Switching the Assist Mode..... 106

- Switching the assist mode with the switch unit 106
- Switching the assist mode with EW-EN100..... 107

Walk Assist Mode..... 107

- Switching to walk assist mode..... 108
- Walk assist mode operation..... 109

Switching Traveling Data Display (SC-E6100) 112

- Resetting the traveling distance..... 114

Switching the Gear Shifting Mode (SC-E6100) 115

Setting Menu (SC-E6100) 116

- Startup 116
- [Clear]..... 119
- [Clock] 120
- [Start mode]..... 122
- [Backlight]..... 123
- [Brightness]..... 124



| | |
|---|------------|
| • [Beep] | 125 |
| • [Unit] | 126 |
| • [Language] | 127 |
| • [Font color] | 129 |
| • [Adjust]..... | 130 |
| • [Shift timing]..... | 134 |
| • [Shifting advice]..... | 135 |
| • [RD protection reset] | 136 |
| • [Exit] | 137 |
| • Updating drive unit backup data | 137 |
| Setting Mode (EW-EN100) | 138 |
| • RD protection reset | 138 |
| • Adjust | 139 |
| Battery LED Error Indications | 142 |
| Cycle Computer Error Messages | 143 |
| • Warnings..... | 143 |
| • Errors | 144 |
| • Maintenance alert | 146 |
| EW-EN100 Error Indication | 146 |
| CONNECTION AND COMMUNICATION WITH DEVICES..... | 147 |
| E-TUBE PROJECT | 147 |
| • Drive unit setting backup function | 148 |
| Wireless Function | 148 |
| • Functions..... | 148 |
| • Connection method | 149 |
| Items Configurable in E-TUBE PROJECT | 150 |
| Connecting to a PC..... | 152 |
| • Connection with single unit | 152 |
| • Connection with all SHIMANO STEPS components | 153 |
| MAINTENANCE..... | 156 |
| Replacing the front chainring | 156 |
| Replacing the chain guard..... | 157 |
| Replacing the Arm Cover..... | 157 |

IMPORTANT NOTICE

- **This dealer’s manual is intended primarily for use by professional bicycle mechanics.**
Users who are not professionally trained for bicycle assembly should not attempt to install the components themselves using the dealer’s manuals.
If any part of the information on the manual is unclear to you, do not proceed with the installation. Instead, contact your place of purchase or a local bicycle dealer for their assistance.
- Make sure to read all instruction manuals included with the product.
- Do not disassemble or modify the product other than as stated in the information contained in this dealer’s manual.
- All dealer’s manuals and instruction manuals can be viewed on-line on our website (<http://si.shimano.com>).
- Please observe the appropriate rules and regulations of the country, state or region in which you conduct your business as a dealer.
- The Bluetooth®-compatible wordmark and logo are registered trademarks owned by Bluetooth SIG, Inc., and are used under agreement by SHIMANO INC. Other trademarks and product names belong to their respective owners.

For safety, be sure to read this dealer’s manual thoroughly before use, and follow it for correct use.

The following instructions must be observed at all times in order to prevent personal injury and physical damage to equipment and surroundings. The instructions are classified according to the degree of danger or damage which may occur if the product is used incorrectly.

| | |
|---|--|
|  DANGER | Failure to follow the instructions will result in death or serious injury. |
|  WARNING | Failure to follow the instructions could result in death or serious injury. |
|  CAUTION | Failure to follow the instructions could cause personal injury or physical damage to equipment and surroundings. |

TO ENSURE SAFETY

DANGER

Be sure to also inform users of the following:

■ Handling the battery

- Do not deform, modify, disassemble or apply solder directly to the battery. Doing so may cause leakage, overheating, bursting, or ignition.
- Do not leave the battery near sources of heat such as heaters, and do not heat the battery or throw it into a fire. Doing so may cause bursting or ignition.
- Do not throw or subject the battery to strong shock. Doing so may cause it to overheat, burst, or ignite.
- Do not place the battery into fresh water or sea water, and do not allow the battery terminals to get wet. Doing so may cause overheating, bursting, or ignition.
- Use the specified battery charger charging and observe the specified charging conditions. Doing otherwise may cause it to overheat, burst, or ignite.

WARNING

- **Be sure to follow the instructions provided in the manuals when installing the product. Intervals between maintenance depend on the use and riding circumstances. Clean the chain with an appropriate chain cleaner regularly. Never use alkali based or acid based solvents, such as rust cleaners. If those solvents are used the chain might break and cause serious injury.**
-  Be sure to wear safety glasses or goggles to protect your eyes while performing maintenance tasks such as replacing parts.
- For information on products not explained in this manual, refer to the manuals provided with each product.
- After reading the dealer's manual thoroughly, keep it in a safe place for later reference.

Be sure to also inform users of the following:

- Be careful not to let yourself be distracted by the cycle computer display while riding the bicycle. Otherwise, you may fall off the bicycle.
- Before riding, check that the wheels are secured. Otherwise, you may fall off the bicycle and be seriously injured.

- Be sufficiently familiar with how to start the power assisted bicycle before riding on busy streets. Otherwise, you may start the bicycle unexpectedly, which may result in an accident.
- Make sure that the light is on during night riding.
- Do not disassemble the product. Disassembling may cause injury.
- When charging the battery while it is installed on the bicycle, do not move the bicycle. The charger's power plug may come loose and not be fully inserted into the electrical outlet, resulting in risk of fire.
- Do not inadvertently touch the drive unit when it has been continuously used for a long period of time. The surface of the drive unit becomes hot and could cause burns.

■ Lithium ion battery

- If any liquid leaking from the battery gets into your eyes, immediately wash the affected area thoroughly with clean water such as tap water without rubbing your eyes, and seek medical advice immediately.
- If this is not done, the battery liquid may damage your eyes.
- Do not recharge the battery in very humid places or the outdoors. Doing so may result in electric shock.
- Do not insert or remove the plug while it is wet. Doing so may result in electric shock. If the inside of the plug is wet, dry it thoroughly before inserting it.
- If the battery does not become fully charged even 2 hours after the designated charging time, immediately unplug the battery from the outlet and contact the place of purchase. Doing otherwise may cause overheating, bursting, or ignition.
- Do not use the battery if it has any noticeable scratches or other external damage. If this is not observed, bursting, overheating or problems with operation may occur.
- The operating temperature ranges for the battery are given below. Do not use it in temperatures outside these ranges. If it is used or stored in temperatures which are outside these ranges, fire, injury or problems with operation may occur.
 1. During discharge: -10°C - 50°C
 2. During charging: 0°C - 45°C

■ For Installation to the Bicycle, and Maintenance:

- Be sure to remove the battery and charging cable before wiring or attaching parts to the bicycle. Otherwise, an electric shock may result.
- Be sure to follow the instructions provided in the manuals when installing the product. It is recommended to use SHIMANO genuine parts only. If bolts and nuts become loose or the product is damaged, the bicycle may suddenly fall over, resulting in a serious injury.

- Intervals between maintenance depend on the use and riding circumstances. Clean the chain with an appropriate chain cleaner regularly. Never use alkali based or acid based solvents, such as rust cleaners. If those solvents are used the chain might break and cause serious injury.

CAUTION

Be sure to also inform users of the following:

- Observe the instructions in the user's manual for the bicycle in order to ride safely.
- Periodically check the battery charger and adapter, particularly the cord, plug, and case, for any damage. If the charger or adapter is broken, do not use it until it has been repaired.
- Use the product according to the directions for use or those of a safety supervisor. Do not allow physically, sensory, or mentally impaired persons, inexperienced persons, or persons with no required knowledge, including children, to use this product.
- Do not allow children to play near the product.
- If any malfunction or trouble occurs, consult the dealer nearest you.
- Never modify the system as this may cause a malfunction in the system.

■ Lithium ion battery

- Do not leave the battery in a place exposed to direct sunlight, inside a vehicle on a hot day, or other hot places. This may result in battery leakage.
- If any leaked fluid gets on your skin or clothes, wash it off immediately with clean water. The leaked fluid may damage your skin.
- Store the battery in a safe place away from the reach of infants and pets.

NOTICE

Be sure to also inform users of the following:

- Be sure to attach dummy plugs to any unused ports.
- For installation and adjustment of the product, consult a dealer.
- The components are designed to be fully waterproof and withstand wet weather riding conditions; however, do not deliberately place them into water.
- Do not clean the bicycle with a high-pressure wash. If water gets into any of the components, operating problems or rusting may result.

- Handle the components carefully, and avoid subjecting them to strong shock.
- Do not turn the bicycle upside down. There is a risk of damage to the cycle computer and shift switches.
- Although the bicycle still functions as a normal bicycle even when the battery is removed, the light will not turn on if it is connected to the electric power system. Be aware that using the bicycle under these conditions will be considered non-observance of the road traffic laws in Germany.
- When carrying the bicycle in a car, remove the battery from the bicycle and place it on a stable surface in the car.
- Before connecting the battery, make sure that there is no water collecting in the area where the battery will be connected (connector), and that it is not dirty.
- When charging the battery while it is mounted on the bicycle, be careful of the following:
 - Before charging, check that there is no water on the charging port of the charging plug.
 - Check that the battery mount is locked before charging.
 - Do not remove the battery from the battery mount while charging.
 - Do not ride with the charger mounted.
 - Close the cap on the charging port when not charging.
 - Fix the bicycle in place when charging, so that it does not tip over.
- It is recommended to use a SHIMANO genuine battery. If using a battery from another company, be sure to read the product manual thoroughly prior to use.
- Some of the important information in this dealer's manual can also be found on the device labels.
- The number written on the battery is necessary when purchasing spare keys for the battery lock. Store it carefully.
- Use a damp, well wrung out cloth, when cleaning the battery and plastic cover.
- If you have any questions about the use and maintenance of the product, consult the place of purchase.
- Contact the place of purchase for updates of the component software. The most up-to-date information is available on the SHIMANO website. For details, refer to the "CONNECTION AND COMMUNICATION WITH DEVICES" section.
- Products are not guaranteed against natural wear and deterioration from normal use and aging.

- For maximum performance we highly recommend SHIMANO lubricants and maintenance products.

■ Connection and communication with PC

Using a PC linkage device to connect a PC to your bicycle (system or component) allows you to use E-TUBE PROJECT to perform a range of tasks, such as customizing individual components or the entire system, or updating firmware.

- PC linkage device: SM-PCE1
- E-TUBE PROJECT: PC application
- Firmware: software inside each component

■ Connection and communication with smartphone or tablet

Connecting your bicycle (system or component) over Bluetooth LE to a smartphone or tablet allows you to use the smartphone/tablet version of E-TUBE PROJECT to perform a range of tasks, such as customizing individual components or the system, or updating firmware.

















- E-TUBE PROJECT: Application for smartphones/tablets
- Firmware: software inside each component

| | |
|---|--|
|  | <p>Disposal information for countries outside the European Union</p> |
| | <p>This symbol is only valid within the European Union.</p> |
| | <p>Follow local regulations when disposing of used batteries. If you are not sure, consult the place of purchase or distributor.</p> |















The actual product may differ from the illustration because this manual is intended mainly to explain the procedures for using the product.

LIST OF TOOLS TO BE USED

The following tools are needed for installation/removal, adjustment, and maintenance purposes.

| Component | Location used/bolt type | Tool | |
|-----------------------------|--|---|--|
| Electric wire | Plug |  | TL-EW02 |
| Cycle Computer | Clamp bolt Mounting bolt Angle adjustment bolt |  | Screwdriver [#2] |
| Switch unit | Clamp bolt |  | 3 mm hexagon wrench |
| Battery mount (BM-E6000) | Key unit |  | Screwdriver [#2] Slotted screwdriver (6.4 mm) |
| | Mount lower case |  | Screwdriver [#2] |
| | Mount upper case |  | Hexalobular [#10] |
| Battery mount (BM-E6010) | Mount lower case Key unit |  | 3 mm hexagon wrench |
| | Key unit cover Mount upper case |  | Screwdriver [#1] |
| Battery mount (BM-E8010) | Mount lower case |  | 3 mm hexagon wrench |
| | |  | 8 mm spanner |
| | Key unit |  | 3 mm hexagon wrench |
| | Key unit cover Mount upper case |  | 2.5 mm hexagon wrench |
| Battery mount (BM-E8020) | Mount lower case Key unit |  | 5 mm hexagon wrench |
| | Mount upper case |  | Screwdriver [#2] |
| | Key cylinder |  | 2 mm hexagon wrench |
| | Key unit cover |  | Screwdriver [#2] |

LIST OF TOOLS TO BE USED

| | | | |
|-------------------------|----------------------------|---|-----------------------------------|
| Speed sensor (SM-DUE10) | Speed sensor mounting bolt |  | 4 mm hexagon wrench |
| | Magnet unit mounting bolt |  | Screwdriver [#2] |
| Speed sensor (SM-DUE11) | Speed sensor mounting bolt |  | Hexalobular [#10] |
| Disc brake rotor | Lock ring |  +  | TL-LR15 + adjustable wrench |
| Drive Unit | Drive unit mounting bolt | - | Contact the bicycle manufacturer. |
| | Drive unit cover |  | Screwdriver [#2] |
| Light cable | Light cable mounting bolt | | |
| Crank arm | Cap |  /  | TL-FC16 / TL-FC18 |
| | Clamp bolt |  | 5 mm hexagon wrench |
| Chainring | Lock ring |  +  | TL-FC39+TL-FC33 |
| | |  +  | TL-FC39+TL-FC36 |
| | Chain guard Arm cover |  | Screwdriver [#2] |

INSTALLING ELECTRICAL PARTS

Names of parts

Rear carrier mount type

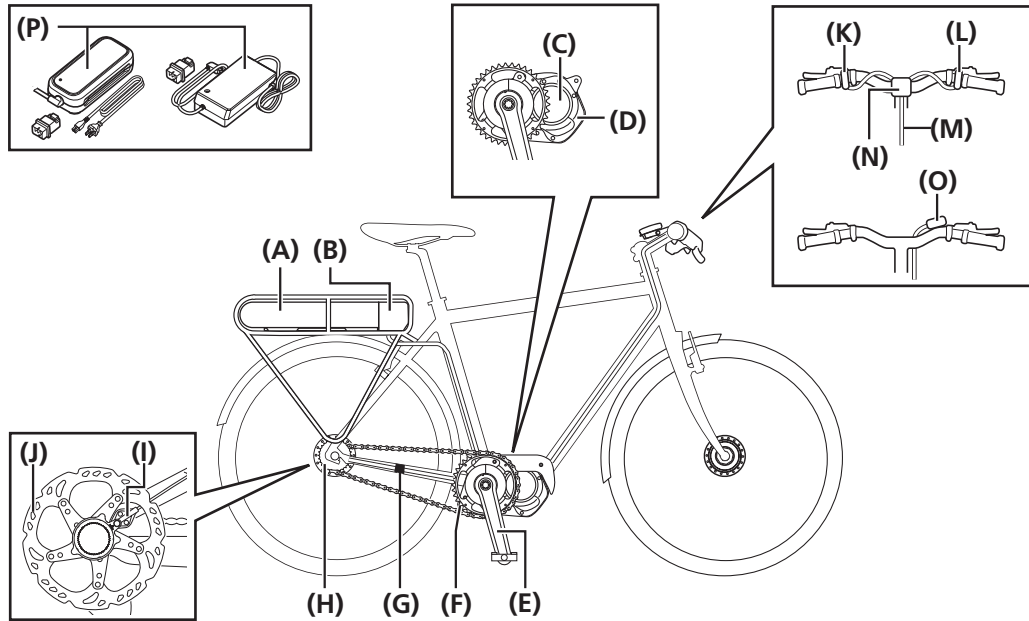

| | | | |
|--------------|---|--------------|--|
| (A) | Battery: BT-E6000 / BT-E6001 | (B) | Battery mount: BM-E6000 |
| (C) | Drive unit: DU-E6100 / DU-E6110 | (D) | Drive unit cover: SM-DUE61-C / SM-DUE61-CC / SM-DUE61-T / SM-DUE61-TC |
| (E) | Crank arm: FC-E6100 / FC-E8000 | (F) | Front chainring: SM-CRE61 |
| (G)*1 | Speed sensor: SM-DUE10 | (H)*2 | Motor unit (internal geared hub DI2): MU-UR500 Rear derailleur (DI2): RD-M8050 |
| (I)*1 | Speed sensor: SM-DUE11 | (J) | Disc brake rotor: RT-EM800 / RT-EM900 |
| (K) | Switch unit (default: assist switch): SW- M8050-L / SW-E6010-L | (L)*2 | Switch unit (default: shift switch): SW- M8050-R / SW-E6010-R |
| (M) | Electric wire: EW-SD50 | (N)*3 | Cycle computer: SC-E6100 |
| (O)*3 | Junction (A) (wireless unit): EW-EN100 | (P) | Battery charger: EC-E6000 / EC-E6002+SM- BCC1 |

*1 Use either (G) or (I). (I) is only when (J) disc brake is mounted.

*2 Electronic gear shifting only.

*3 Use either (N) or (O).

Down tube mount type

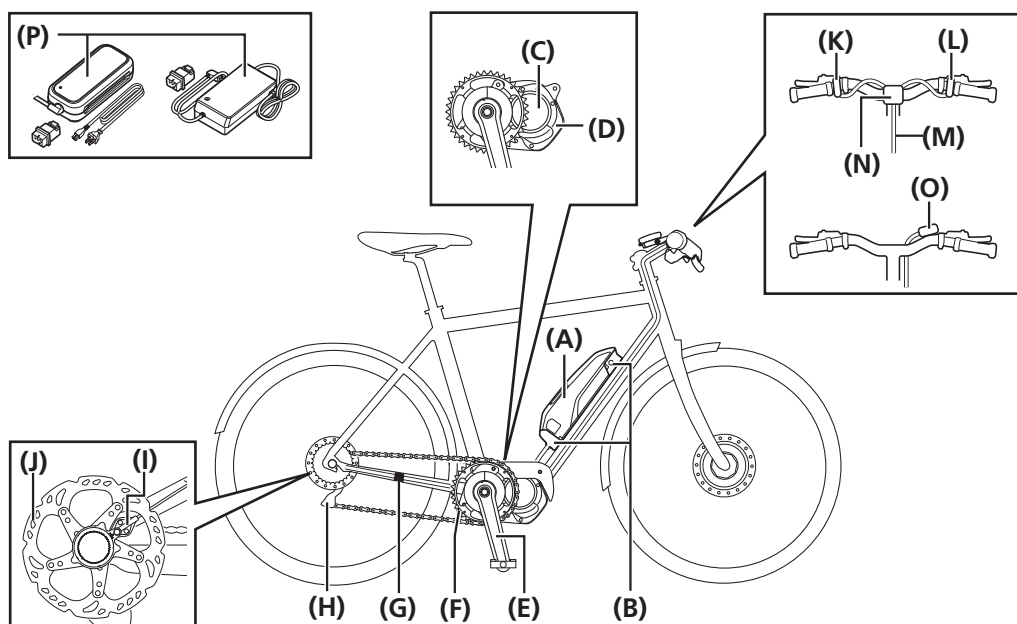

| | | | |
|--------------|---|--------------|--|
| (A) | Battery: BT-E6010 / BT-E8010 / BT-E8014 | (B) | Battery mount: BM-E6010 / BM-E8010 |
| (C) | Drive unit: DU-E6100 / DU-E6110 | (D) | Drive unit cover: SM-DUE61-C / SM-DUE61-CC / SM-DUE61-T / SM-DUE61-TC |
| (E) | Crank arm: FC-E6100 / FC-E8000 | (F) | Front chainring: SM-CRE61 |
| (G)*1 | Speed sensor: SM-DUE10 | (H)*2 | Motor unit (internal geared hub DI2): MU-UR500 Rear derailleur (DI2): RD-M8050 |
| (I)*1 | Speed sensor: SM-DUE11 | (J) | Disc brake rotor: RT-EM800 / RT-EM900 |
| (K) | Switch unit (default: assist switch): SW- M8050-L / SW-E6010-L | (L)*2 | Switch unit (default: shift switch): SW- M8050-R / SW-E6010-R |
| (M) | Electric wire: EW-SD50 | (N)*3 | Cycle computer: SC-E6100 |
| (O)*3 | Junction (A) (wireless unit): EW-EN100 | (P) | Battery charger: EC-E6000 / EC-E6002+SM- BCC1 |

*1 Use either (G) or (I). (I) is only when (J) disc brake is mounted.

*2 Electronic gear shifting only.

*3 Use either (N) or (O).

Built-in type

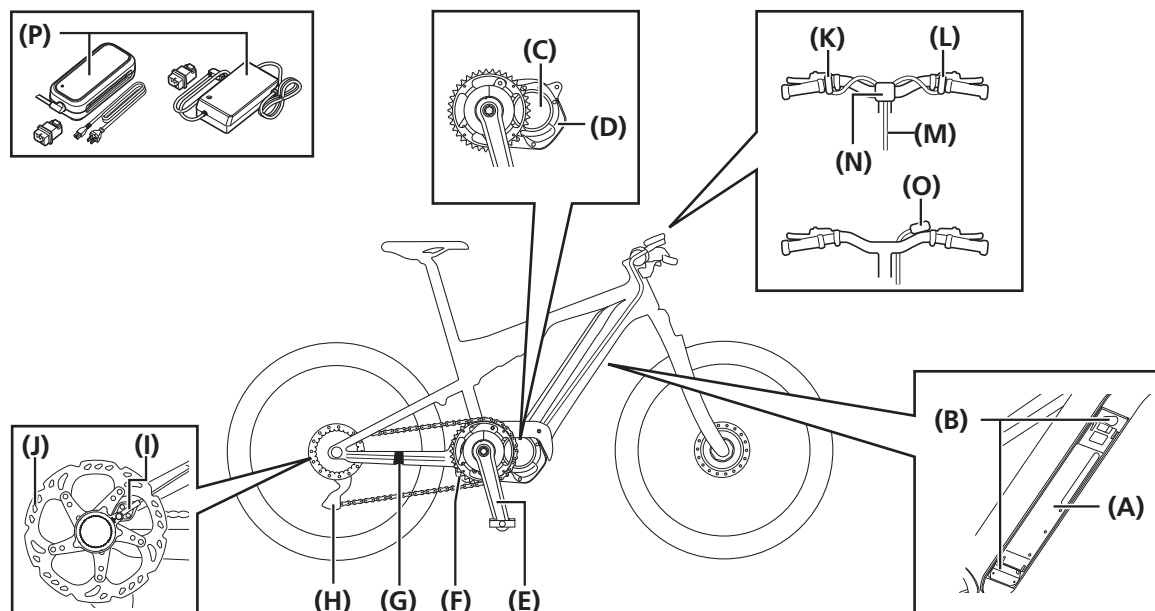

| | | | |
|--------------|---|--------------|--|
| (A) | Battery: BT-E8020 | (B) | Battery mount: BM-E8020 |
| (C) | Drive unit: DU-E6100 / DU-E6110 | (D) | Drive unit cover: SM-DUE61-C / SM-DUE61-CC / SM-DUE61-T / SM-DUE61-TC |
| (E) | Crank arm: FC-E6100 / FC-E8000 | (F) | Front chainring: SM-CRE61 |
| (G)*1 | Speed sensor: SM-DUE10 | (H)*2 | Motor unit (internal geared hub DI2): MU-UR500 Rear derailleur (DI2): RD-M8050 |
| (I)*1 | Speed sensor: SM-DUE11 | (J) | Disc brake rotor: RT-EM800 / RT-EM900 |
| (K) | Switch unit (default: assist switch): SW- M8050-L / SW-E6010-L | (L)*2 | Switch unit (default: shift switch): SW- M8050-R / SW-E6010-R |
| (M) | Electric wire: EW-SD50 | (N)*3 | Cycle computer: SC-E6100 |
| (O)*3 | Junction (A) (wireless unit): EW-EN100 | (P) | Battery charger: EC-E6000 / EC-E6002+SM- BCC1 |

*1 Use either (G) or (I). (I) is only when (J) disc brake is mounted.

*2 Electronic gear shifting only.

*3 Use either (N) or (O).

Overall Wiring Diagram

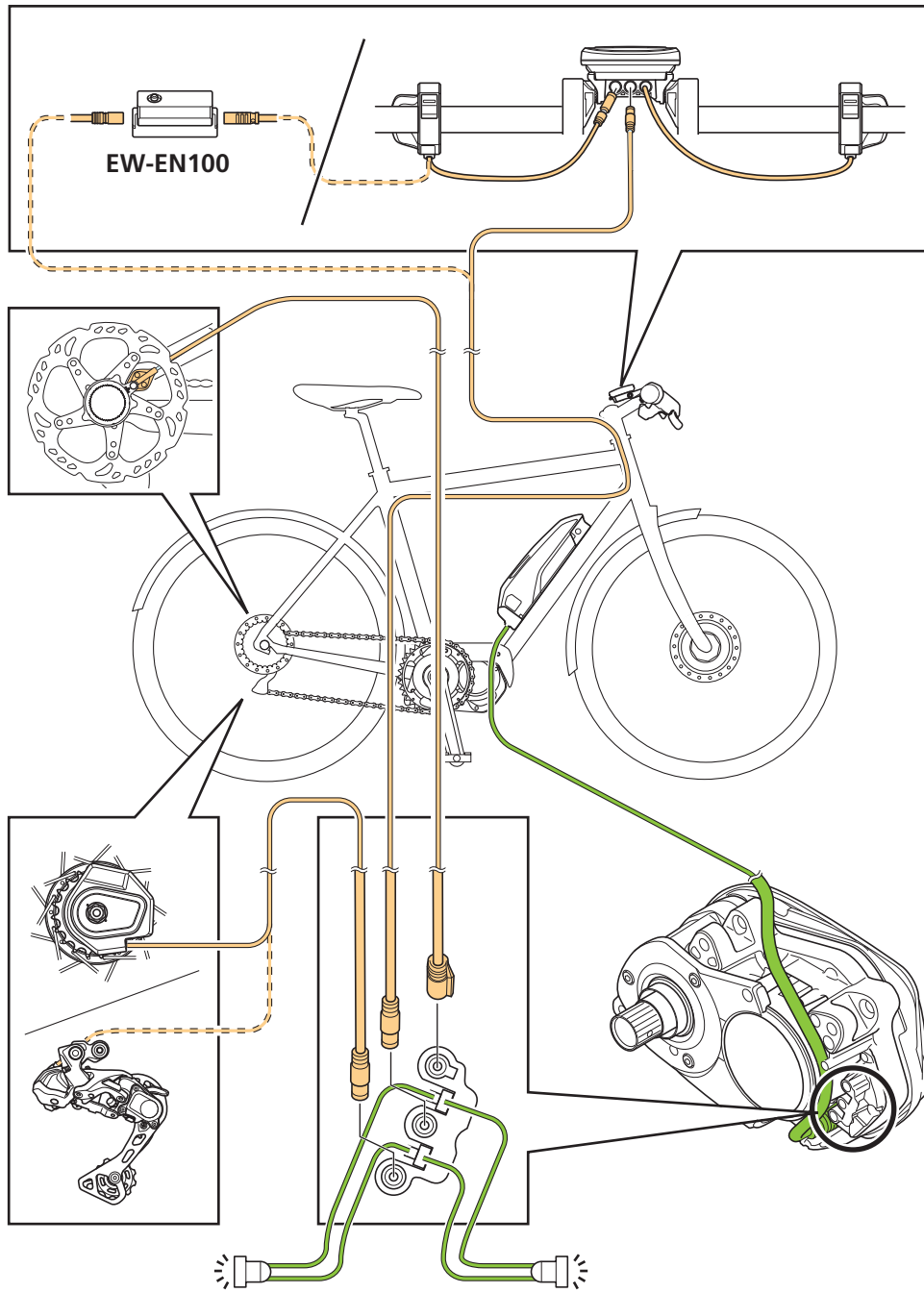

TECH TIPS

- The maximum cable length of the electric wire (EW-SD50) is 1,600 mm.

Specifications

| | | | |
|---|---|-------------------------------|-------------------------------------|
| Operating temperature range: Discharging | -10 - 50°C | Battery type | Lithium ion battery |
| Operating temperature range: Charging | 0 - 40°C | Nominal capacity | Refer to the battery user's manual. |
| Storage temperature | -20 - 70°C | Rated voltage | 36 V DC |
| Storage temperature (Battery) | -20 - 60°C | Drive Unit | Midship |
| Charging voltage | 100 - 240 V AC | Motor type | Brushless DC |
| Charging time | Refer to the battery charger user's manual. | Rated drive unit power | 250 W |

TECH TIPS

- The maximum speed provided by assist is set by the manufacturer, but may vary depending on the conditions under which the bicycle is used.
- The latest manual information can be accessed on our website (<http://si.shimano.com>).

Handling Electric Wires

Be sure to use the SHIMANO original tool to remove and insert electric wires.

NOTICE

- When connecting and disconnecting electric wires, do not forcibly bend the plug part. It may result in a poor connection.

Connecting the electric wire

Connect the electric wire to the E-TUBE port.

1. Set the plug part of the electric wire to the SHIMANO original tool.

If there is a protrusion on the plug part of the electric wire, set it aligned with the groove on the SHIMANO original tool.

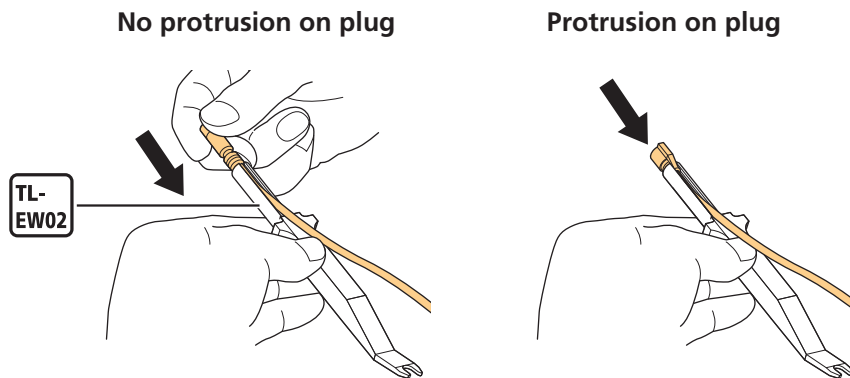

2. Insert the plug part on the electric wire into the E-TUBE port.

Push it straight in until you feel it click into place.

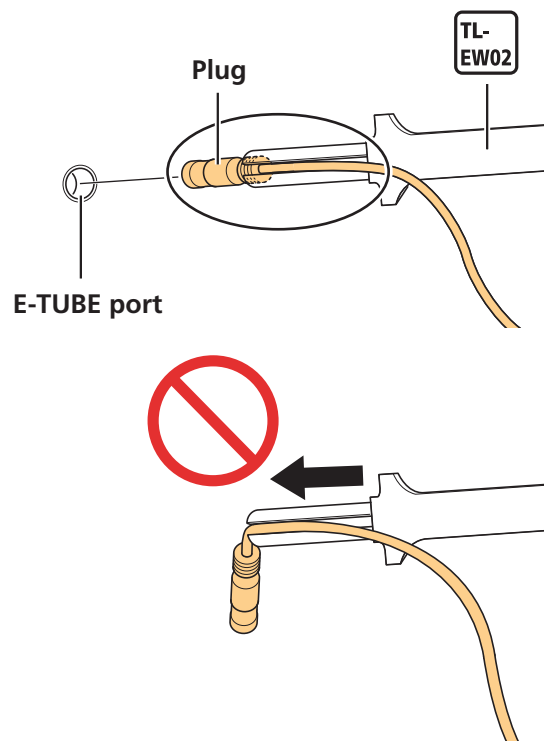

Disconnecting the electric wire

1. Disconnect the electric wire.

(1) Insert the SHIMANO original tool into the plug part of the electric wire.

(2) Disconnect the electric wire from the E-TUBE port.

* As shown in the figure, move the SHIMANO original tool like a lever with part (A) as the axis to disconnect. If there is limited space to insert the tool, lift the SHIMANO original tool straight up and disconnect the electric wire.

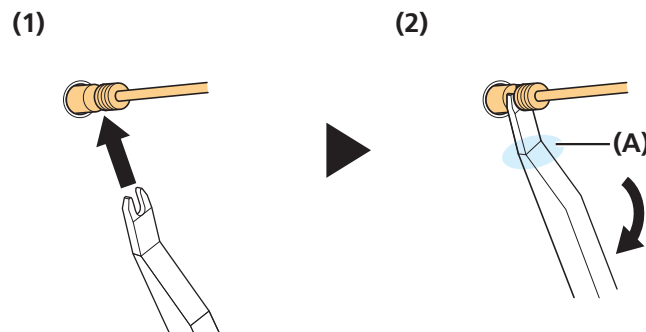

Installing the Cycle Computer/Junction (A)

SC-E6100

The bracket used to secure the cycle computer to the handlebar, and the cycle computer itself are separate parts.

▶ Installing the bracket and cycle computer

1. Check the diameter of the handlebar to determine whether an adapter is needed, and then select the clamp bolt.

| ϕA | $\phi B - \phi A$ | Bracket | Clamp bolt |
|-----------|-------------------|---------------|-----------------|
| 23.4-24 | 0-1.1 | Required | Length: 15.5 mm |
| 24-25.5 | 0-1.1 | Required | Length: 20 mm |
| 31.3-31.9 | 0-0.6 | Not necessary | Length: 20 mm |

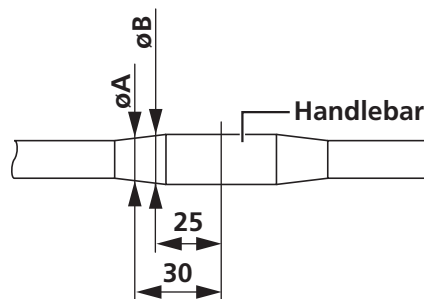

2. If adapters are required, push them along to the center of the handlebar.

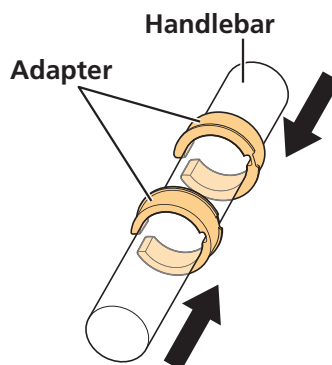

3. Temporarily install the bracket.

- (1) Push the clamp area open, and then install the bracket to the center of the handlebar.
- (2) Temporarily install the clamp bolt (of the length selected in step 1).

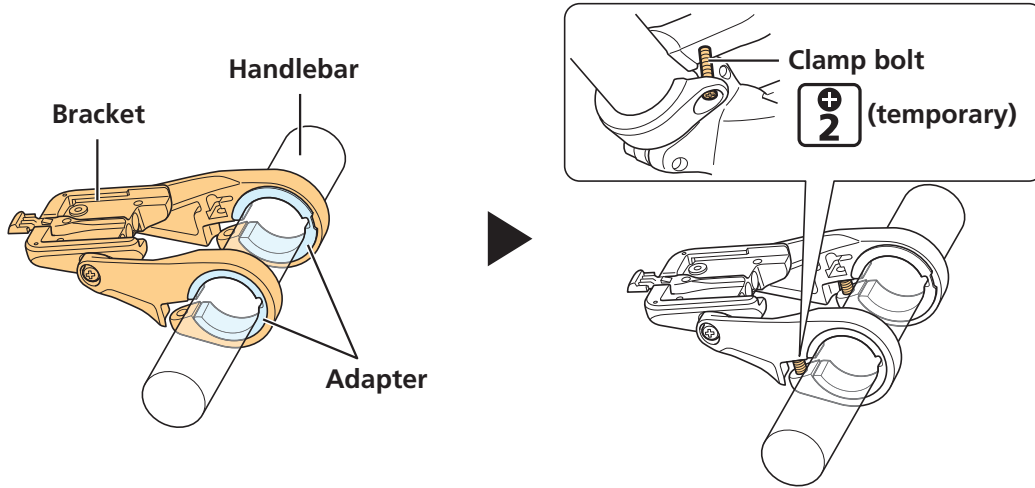

4. Install the cycle computer to the bracket.

- Slide the cycle computer and install it to the bracket.
Insert it firmly until you hear it click.

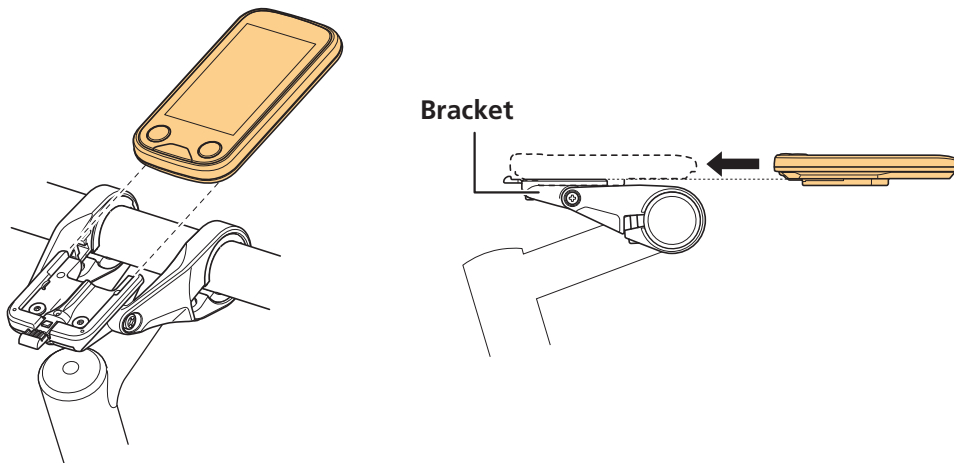

5. Secure the cycle computer if necessary.

If the cycle computer will not be secured to the bracket, this step is not necessary.

- (1) Stand the cycle computer and bracket up on the stem (as though you are turning the cycle computer around).
- (2) Insert the square nut into the bracket.
- (3) Tighten the mounting bolt.

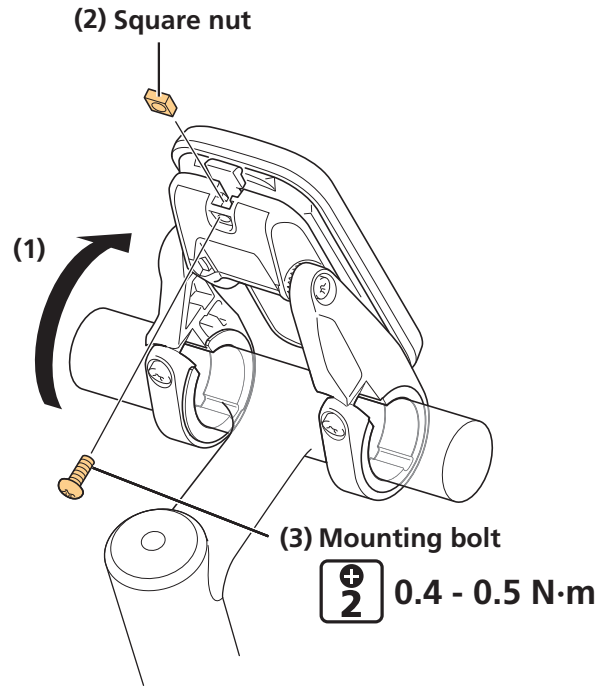

TECH TIPS

- This procedure is used to secure the cycle computer to the bracket, so that it cannot be easily removed. This is useful for displaying the product.
- Ask the user if they will secure the cycle computer when the product is delivered. If necessary, explain how to do as (as described above).

6. Secure the bracket to the handlebar.

- (1) Return the cycle computer to its installation position (the cycle computer was stood up on the stem in step 4).
- (2) Secure the bracket.

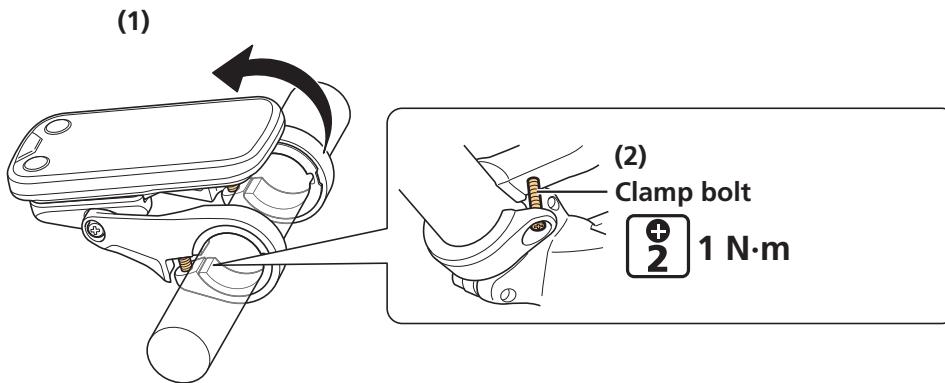

▶ Removing the cycle computer

1. Remove the mounting bolt on the bottom side of the bracket.

If the cycle computer was not secured, this procedure is not necessary. Skip to step 2.

- (1) Loosen the clamp bolt, and then stand the cycle computer and bracket up on the stem (as though you are turning the cycle computer around).
- (2) Remove the mounting bolt and square nut.

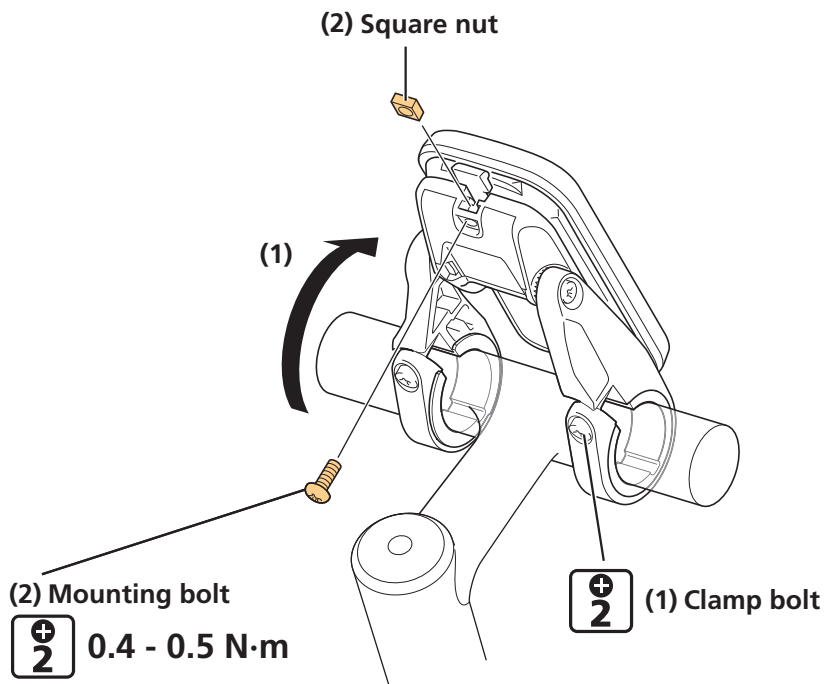

2. Remove the cycle computer from the bracket.

Slide the cycle computer to the front while pushing the bracket lever down to remove it.

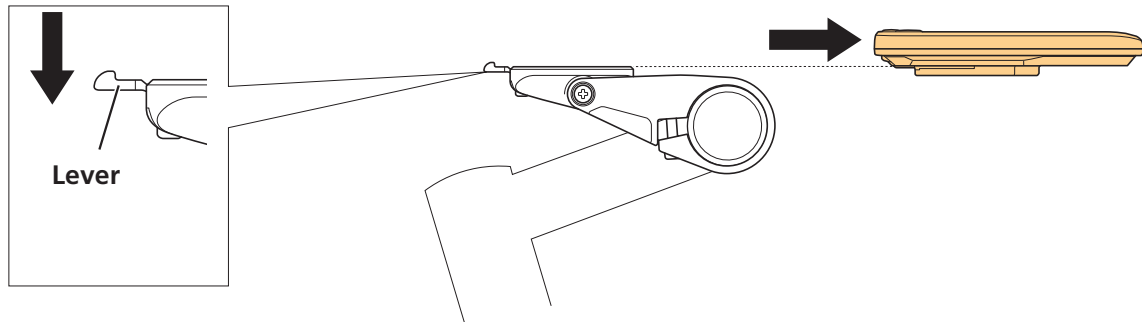

▶ Adjusting the installation angle

1. Adjust the installation angle of the cycle computer.

- (1) Loosen the angle adjustment bolt.
- (2) After adjusting the angle of the cycle computer to make it easier to see while riding, tighten the angle adjustment bolt.

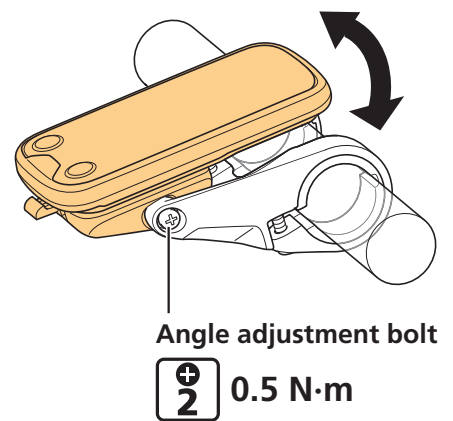

EW-EN100

EW-EN100 is junction (A) with simple operation/display functionality.

Instead of a cycle computer, install it in a location around the cockpit from which the LED can be seen while riding.

This section explains how to install it to the brake hose. It can be installed to the brake outer casing using the same procedure.

NOTICE

EW-EN100 Installation location

- As shown in the figure, install EW-EN100 so that it does not reach the side of the frame. Otherwise, it could be damaged if the bicycle tips over and it is pinched between the frame and curb.

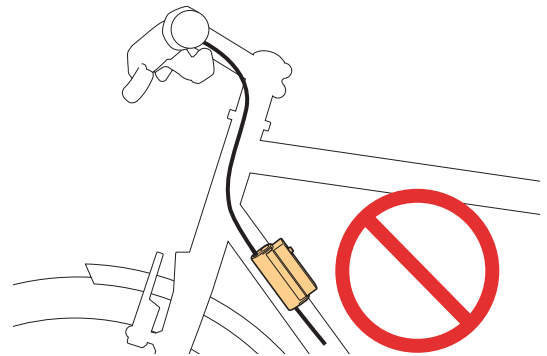
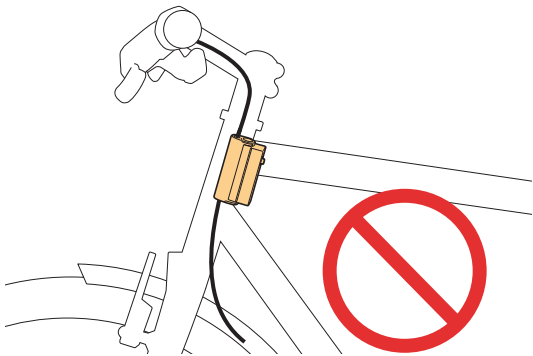
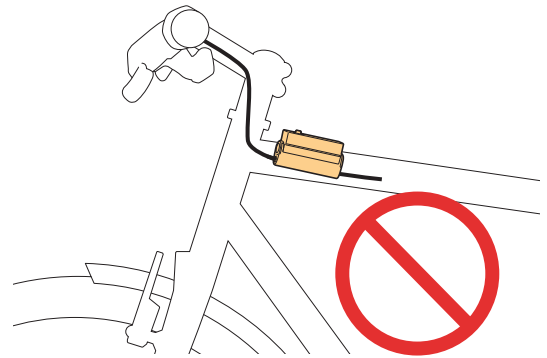
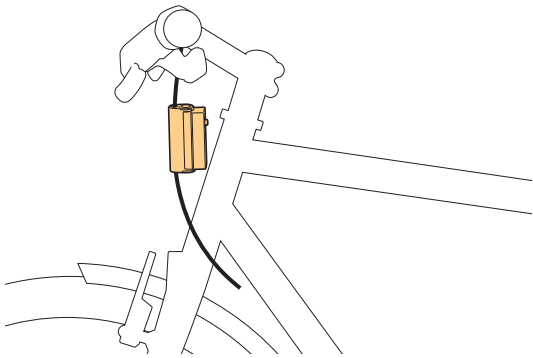

1. Determine the EW-EN100 installation location, and then set the adapter.

- (1) Open up the adapter and set it to the brake hose.
- (2) Bend the adapter along the brake hose.

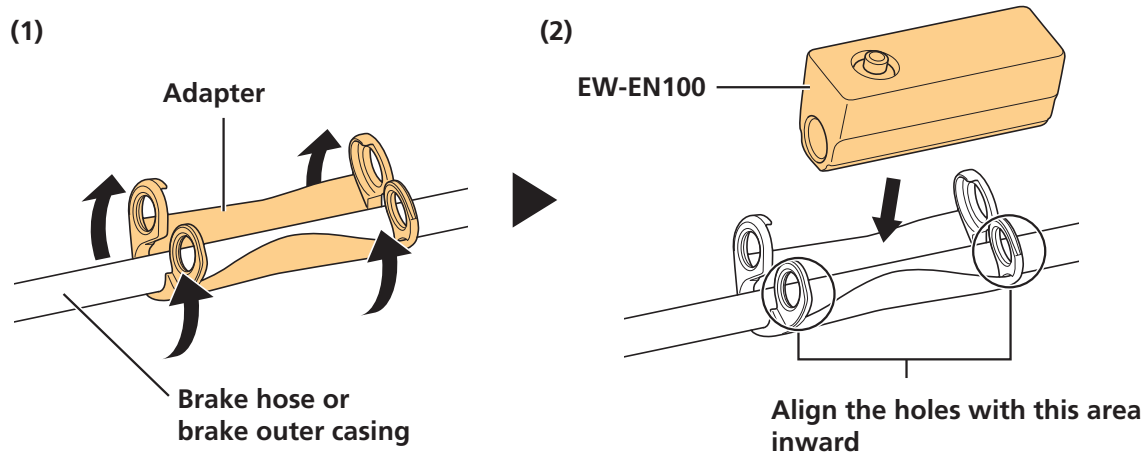

2. As shown in the figure, set EW-EN100 and then connect the electric wire or dummy plug.

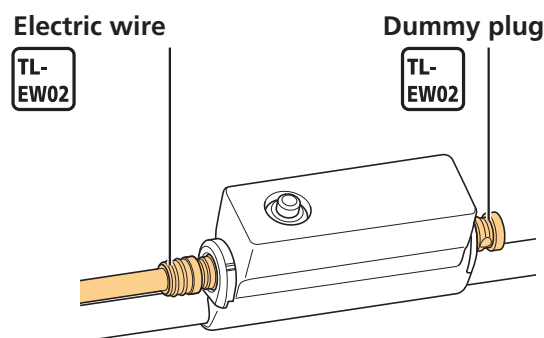

NOTICE

- Be sure to connect either an electric wire or a dummy plug to the two E-TUBE ports on EW-EN100. Connecting both will secure EW-EN100 to the brake hose or brake outer casing.

TECH TIPS

- When removing it, reverse the procedure.

Installing the Switch Unit (SW-E6010)

- Install the assist switch and shift switch (for electronic gear shifting) to the handlebar.
- Install SW-E6010-L to the left side of the handlebar (the assist side by default) and SW-E6010-R to the right side (the shift side by default).
- SW-E6010 can be installed to Ø22.2 handlebars.

1. Temporarily attach the cord bands.

Cord bands are included with the switch unit.

- Temporarily attach the cord bands to the switch unit cable.
- Adjust the number of cord bands according to the length of the handlebar.

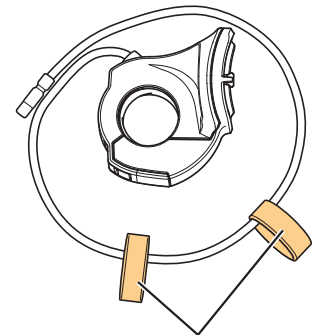

Cable band

2. Push the cord bands and switch unit along from the edge of the handlebar.

For the switch unit, the electric wire must be facing downward.

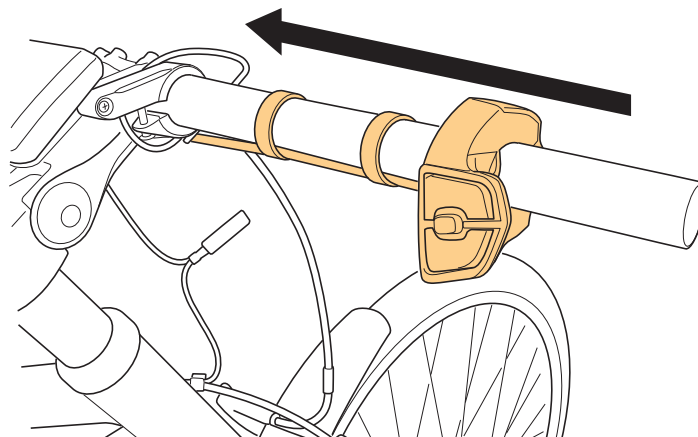

3. Open the mounting bolt cover, and then tighten the mounting bolt.

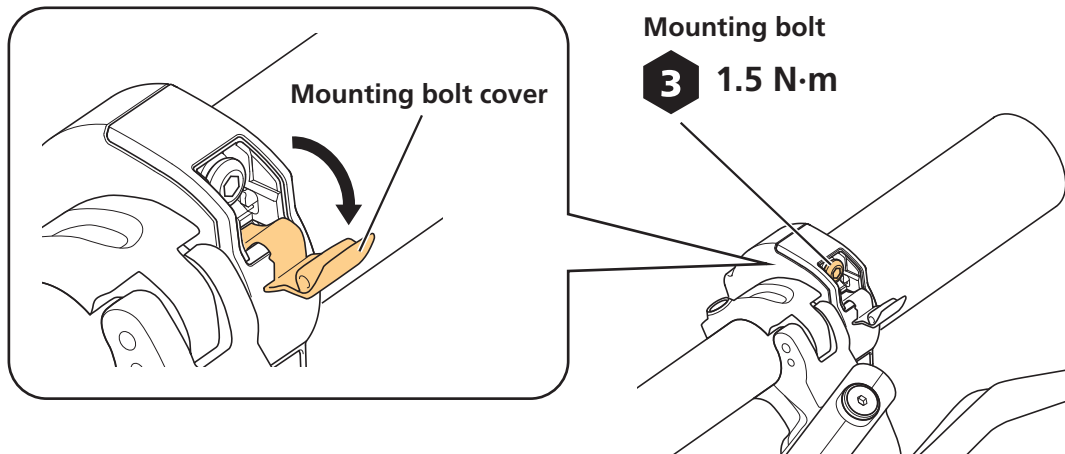

TECH TIPS

- When removing it, reverse the procedure.

Installing the Switch Unit (SW-M8050)

- Install the assist switch and shift switch (for electronic gear shifting) to the handlebar.
- Install SW-M8050-L to the left side of the handlebar (the assist side by default) and SW-M8050-R to the right side (the shift side by default).
- SW-M8050 can be installed to $\varnothing 22.2$ to $\varnothing 22.5$ handlebars.

1. Confirm the wiring method for the handlebar.

If the electric wire to the switch unit will be inside the handlebar, wire it ahead of time.

2. Push the switch unit along the handlebar.

To place the electric wire inside the handlebar, pass the electric wire between the switch unit and handlebar.

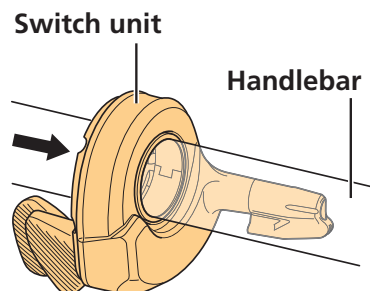

3. Secure the switch unit.

- (1) Adjust the installation location and angle of the switch unit.
- (2) Tighten the clamp bolt.

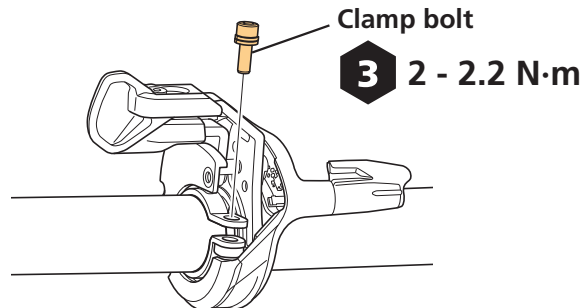

4. Adjust the locations of lever X and lever Y.

- (1) Loosen the lever mounting bolts.
- (2) Adjust the locations of lever X and lever Y so that they are easy to operate.
- (3) Tighten the lever mounting bolts.

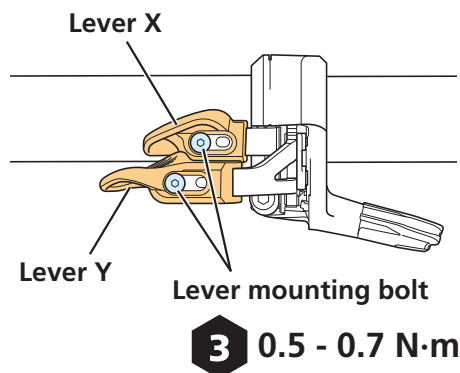

Connecting the electric wire

1. Remove the cable cap.

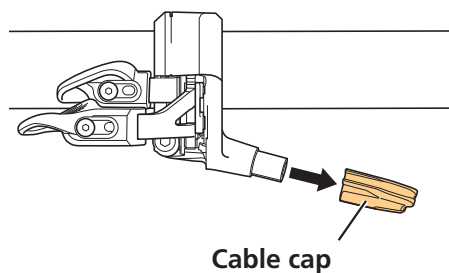

2. Connect the electric wire to the switch unit.

- (1) Pass the electric wire through the cable cap.
- (2) Connect the electric wire to the switch unit.

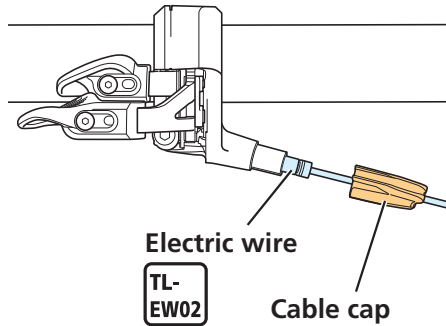

NOTICE

- If the electric wire is connected to the switch unit without passing it through the cable cap, the plug part of the electric wire may be damaged.

3. Install the cable cap.

When routing the electric wire in the direction of the stem
Install as shown in the figure.

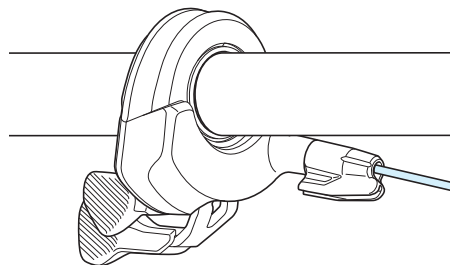

When routing the electric wire in the direction of the tip of the handlebar and placing it inside

Route the electric wire as shown below.

- (1) After installing the cable cap, route the electric wire along the guide on the cable cap.
- (2) Draw the electric wire into the handlebar.

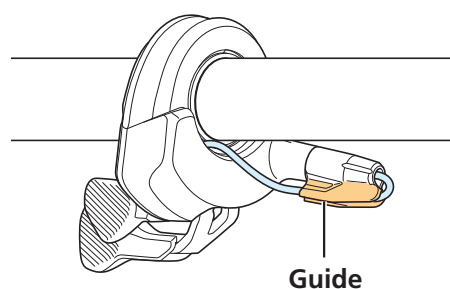

Wiring around the Cockpit (SC-E6100)

There are three E-TUBE ports in the SC-E6100 bracket. One E-TUBE port must be connected to the drive unit. At least one of the remaining two E-TUBE ports must be connected to the switch unit. As an example, this section explains how to connect two switch units.

NOTICE

- Be sure to attach dummy plugs to any unused E-TUBE ports.

1. Wire around the cockpit.

- Connect the electric wires between SC-E6100 and the switch units.
- Switch units and drive units can be connected to any of the E-TUBE ports on SC-E6100. However, it is recommended to connect the left and right ports to each switch unit, and the center port to the cycle computer (as shown in the figure).

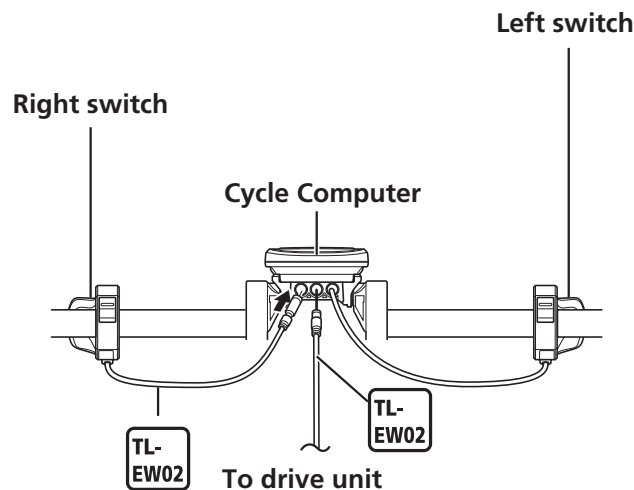

2. Prepare to wire to the drive unit.

Pass the following wires through the frame, and leave them hanging from the drive unit installation section on the frame.

- Electric wire to connect SC-E6100 and the drive unit
- Electric wire to connect the light and drive unit if installing a light that will use the main battery as the power source

Example: Routing the electric wire

This section presents an example of routing an electric wire around the cockpit when using an SW-E6010 switch unit.

TECH TIPS

- Cord bands are included with SW-E6010.
- Cable bands are included with SC-E6100.

► When using cord bands

1. Secure the switch unit's electric wire.

Determine the locations of the cord bands, and then secure the electric wire in place along the handlebar so that there is no slack.

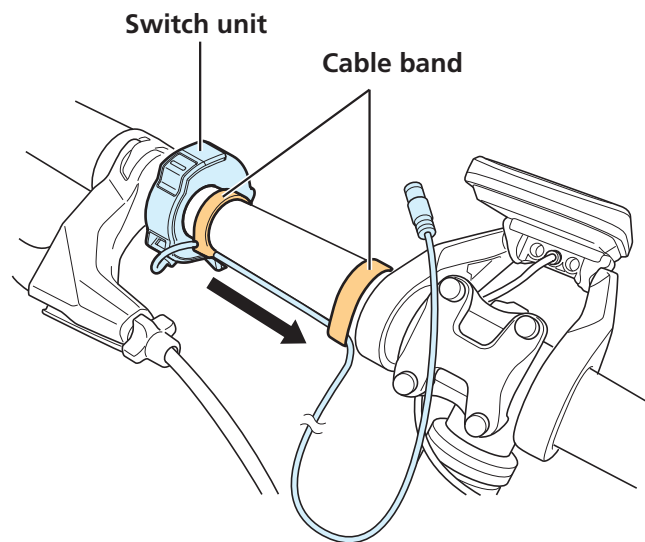

2. Connect the electric wire to the E-TUBE port on the bracket.

Wrap any slack around the portion of the handlebar between the cycle computer and stem prior to connecting.

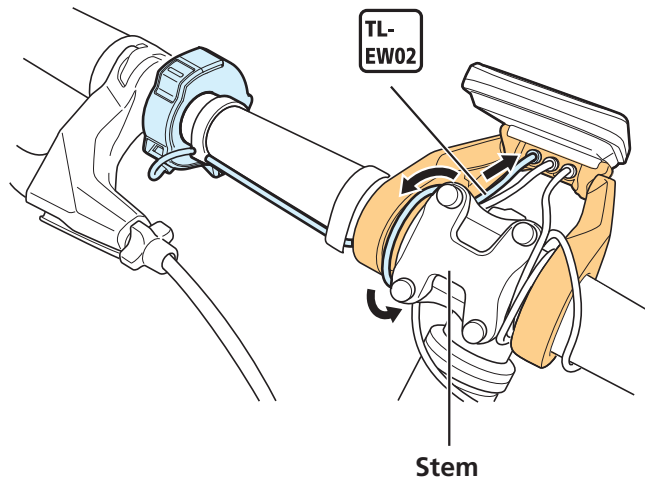

▶ When using cord bands and cable bands

1. Secure the switch unit's electric wire.

Determine the locations of the cord bands, and then secure the electric wire in place along the handlebar so that there is no slack.

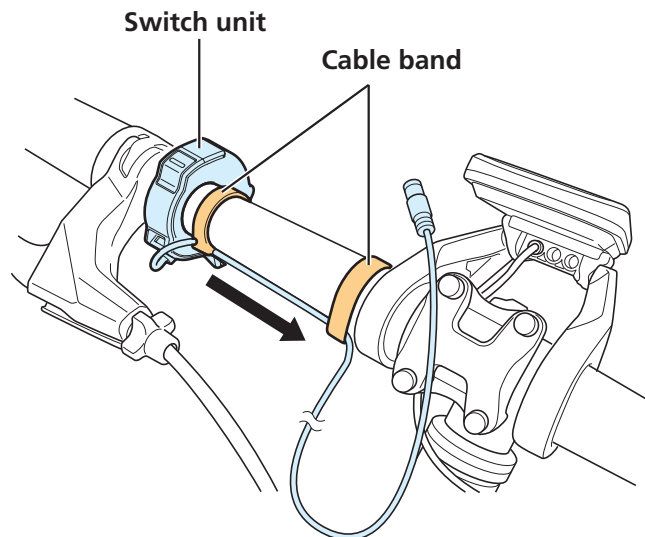

2. Use the cable bands to bind the brake outer casing and electric wires together.

Use the cable bands to bind the brake outer casing and following electric wires.

- Switch unit's electric wire
- Electric wire to connect the cycle computer and drive unit

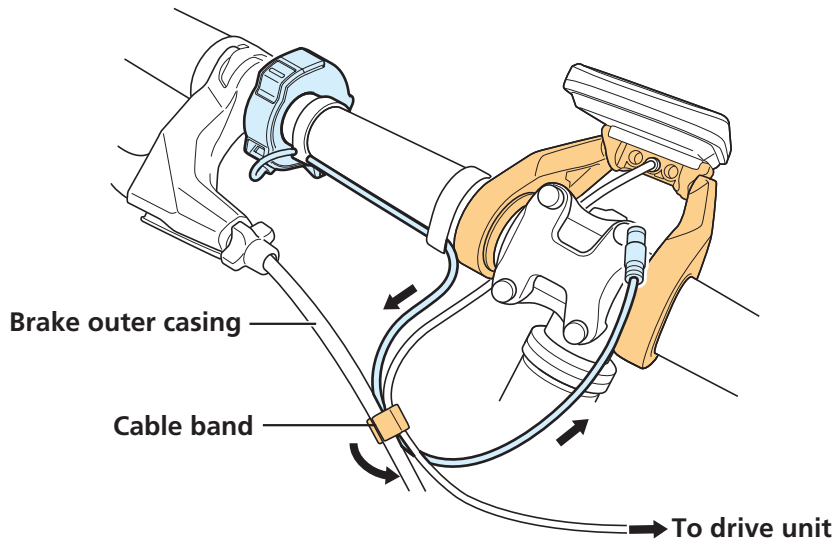

3. Connect the electric wire to the E-TUBE port on the bracket.

Wrap any slack around the portion of the handlebar between the cycle computer and stem prior to connecting.

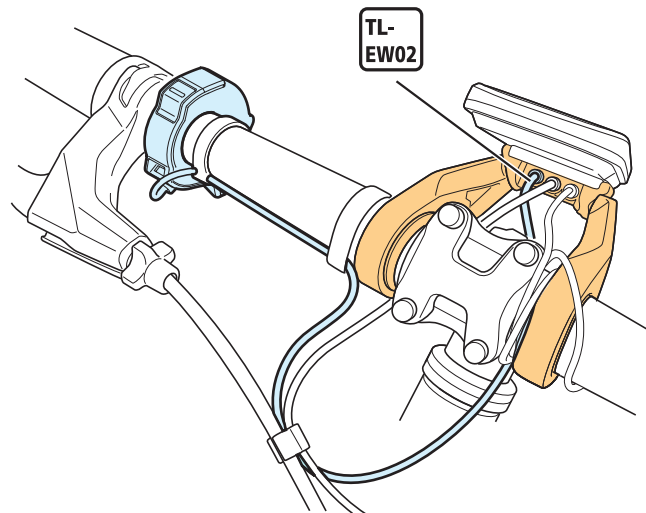

Wiring around the Cockpit (EW-EN100)

As an example, this section explains how to connect a switch unit to EW-EN100.

1. Wire around the cockpit.

To connect the switch unit, use the electric wire to connect EW-EN100 and the switch unit.

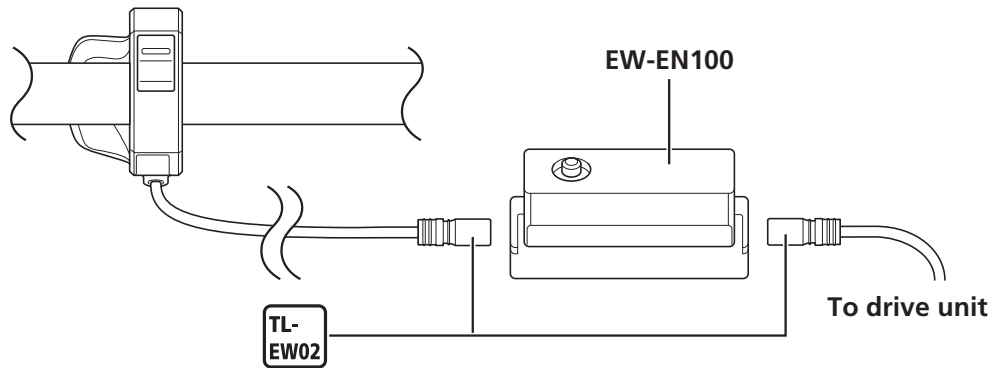

2. Prepare to wire to the drive unit.

Pass the following wires through the frame, and leave them hanging from the drive unit installation section on the frame.

- Electric wire connecting EW-EN100 and the drive unit
- Electric wire to connect the light and drive unit if installing a light that will use the main battery as the power source

Example: Routing the electric wire

This section presents an example of routing an electric wire around the cockpit when using an SW-E6010 switch unit.

1. Secure the switch unit's electric wire.

Determine the locations of the cord bands, and then secure the electric wire in place along the handlebar so that there is no slack.

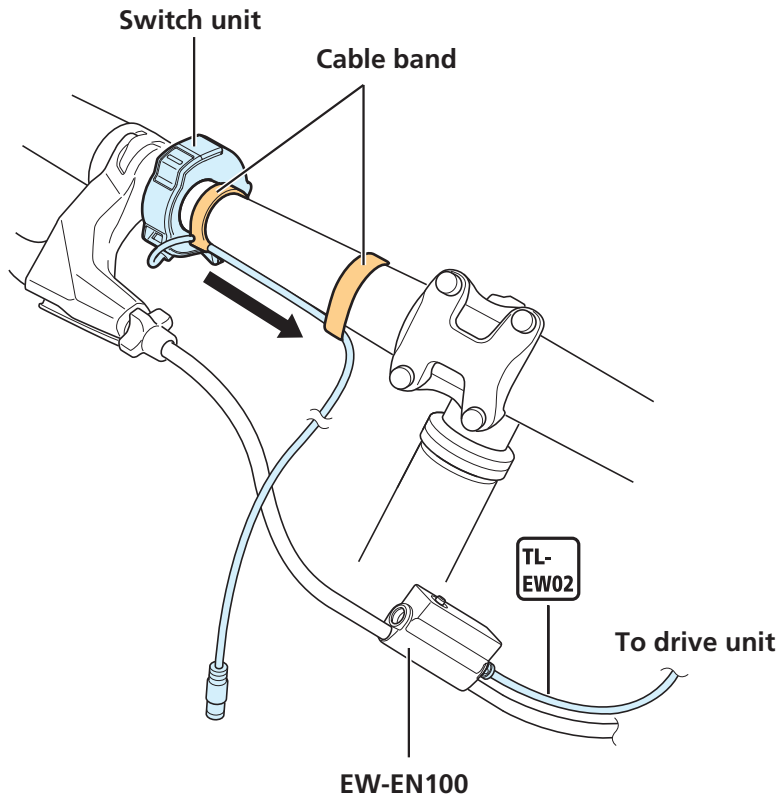

2. Connect the electric wire to the E-TUBE port on EW-EN100.

If necessary, use a cable band to secure the electric wire connecting the switch unit and EW-EN100 to either the brake hose or brake outer casing.

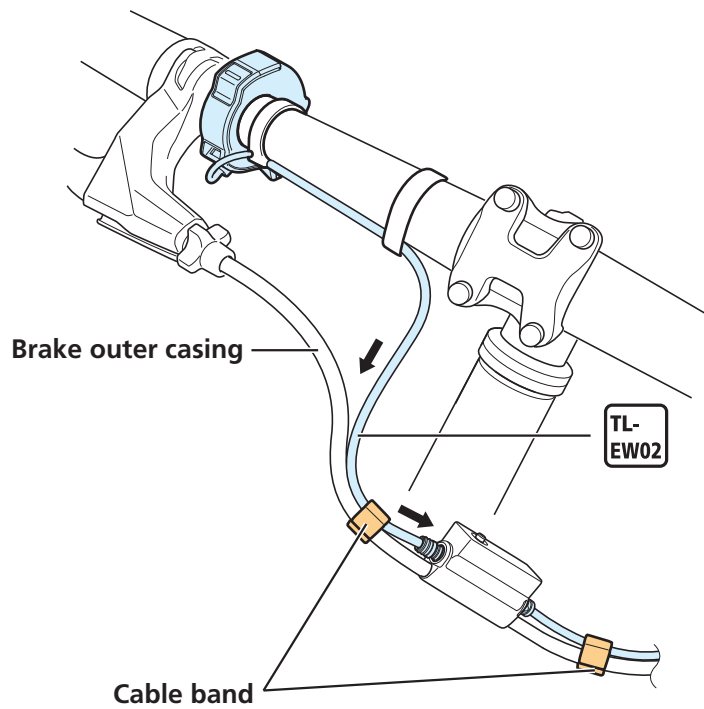

Installing the Battery Mount

BM-E6000

1. Install the mount lower case to the key unit.

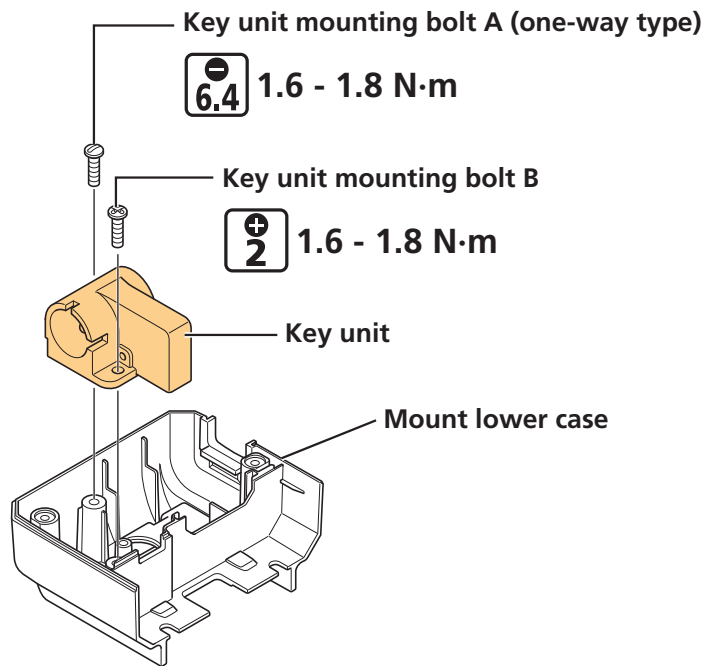

2. Set the plug unit to the mount lower case, and install it to the battery rail.

- (1) Set the plug unit to the mount lower case.
- (2) Set the battery rail to the mount lower case. Be careful not to pinch the power cord between the mount lower case and battery rail.
- (3) Secure the battery rail.

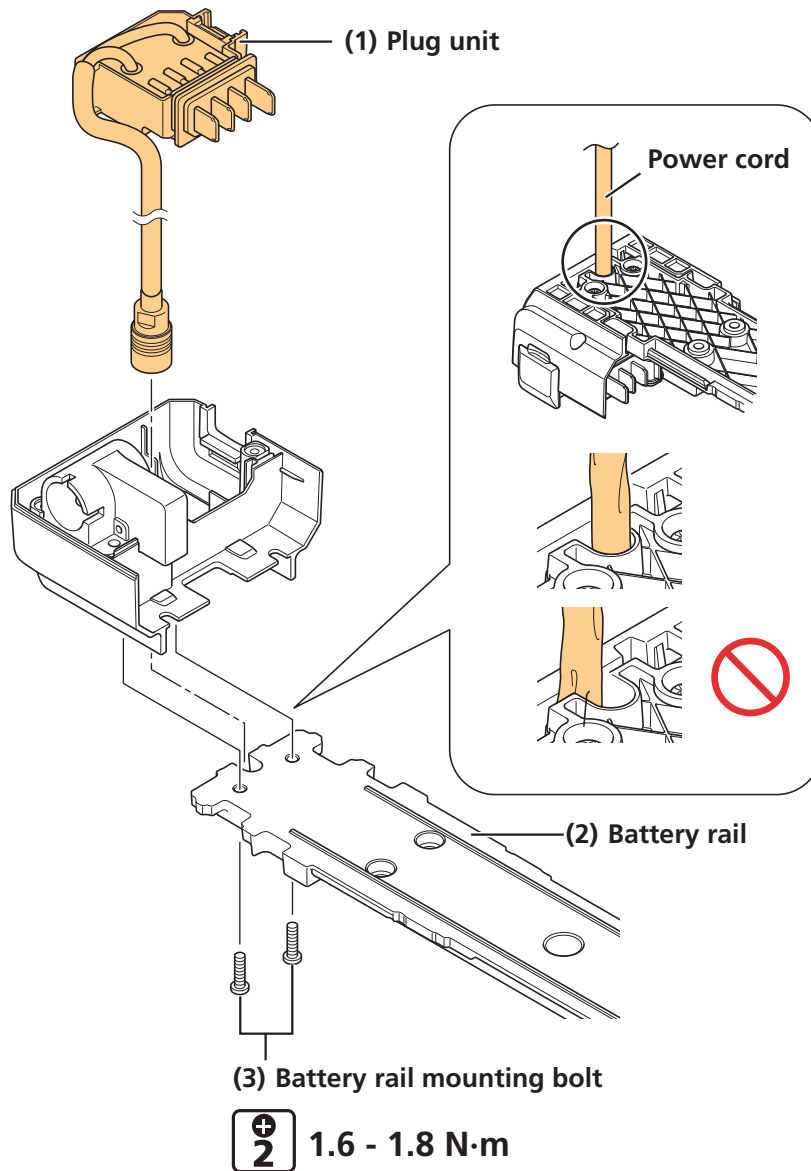

3. Install the mount upper case.

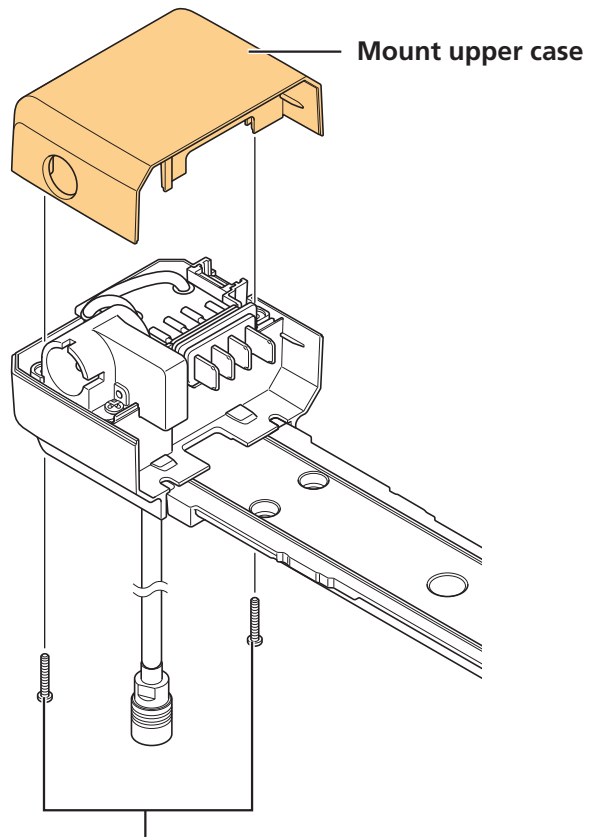

Mount upper case mounting bolt

10 1.1 - 1.3 N·m

4. Install the battery mount to the rear carrier.

- (1) Set the battery mount aligned with the mounting hole on the rear carrier.
- (2) Secure the battery mount. Use the bicycle manufacturer's standard tightening torque.
- (3) After installing the battery mount, perform the following.
 - Firmly close the charging port cap.
 - Pass the power cord through the frame and leave it hanging over the drive unit installation area.

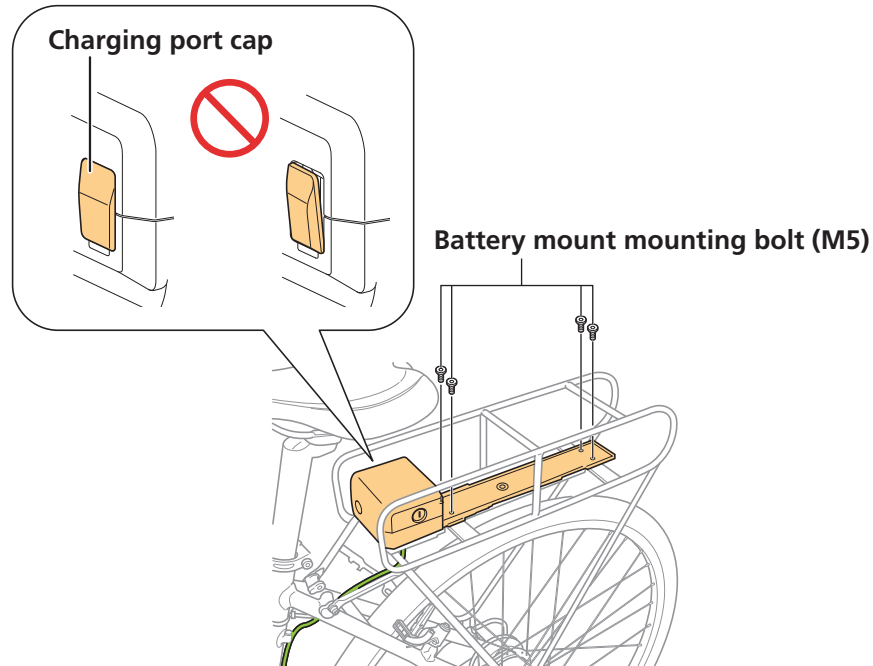

NOTICE

- Battery mount mounting bolts (M5) are not included with SHIMANO products. Use the bolt supplied by the bicycle manufacturer. Contact the bicycle manufacturer for the tightening torque.

BM-E6010

1. Install the mount lower case.

Secure the mount lower case on the lower side of the down tube.

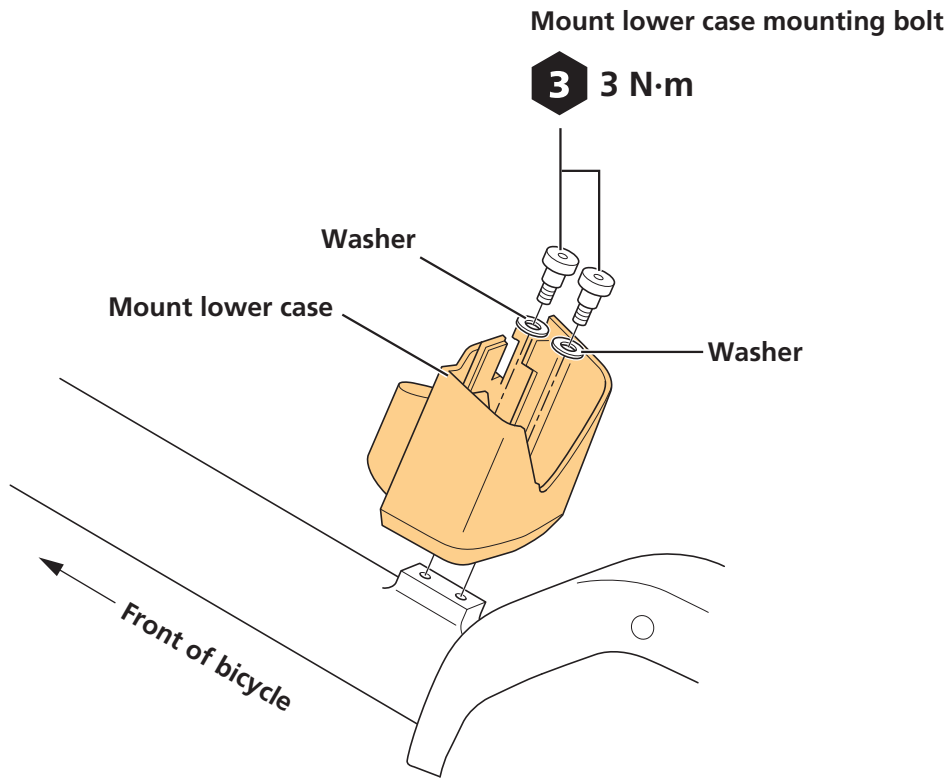

2. Temporarily install the key unit, and then adjust the location of the key unit.

- (1) Temporarily install the key unit on the upper side of the down tube.
- (2) Adjust the key unit installation location.

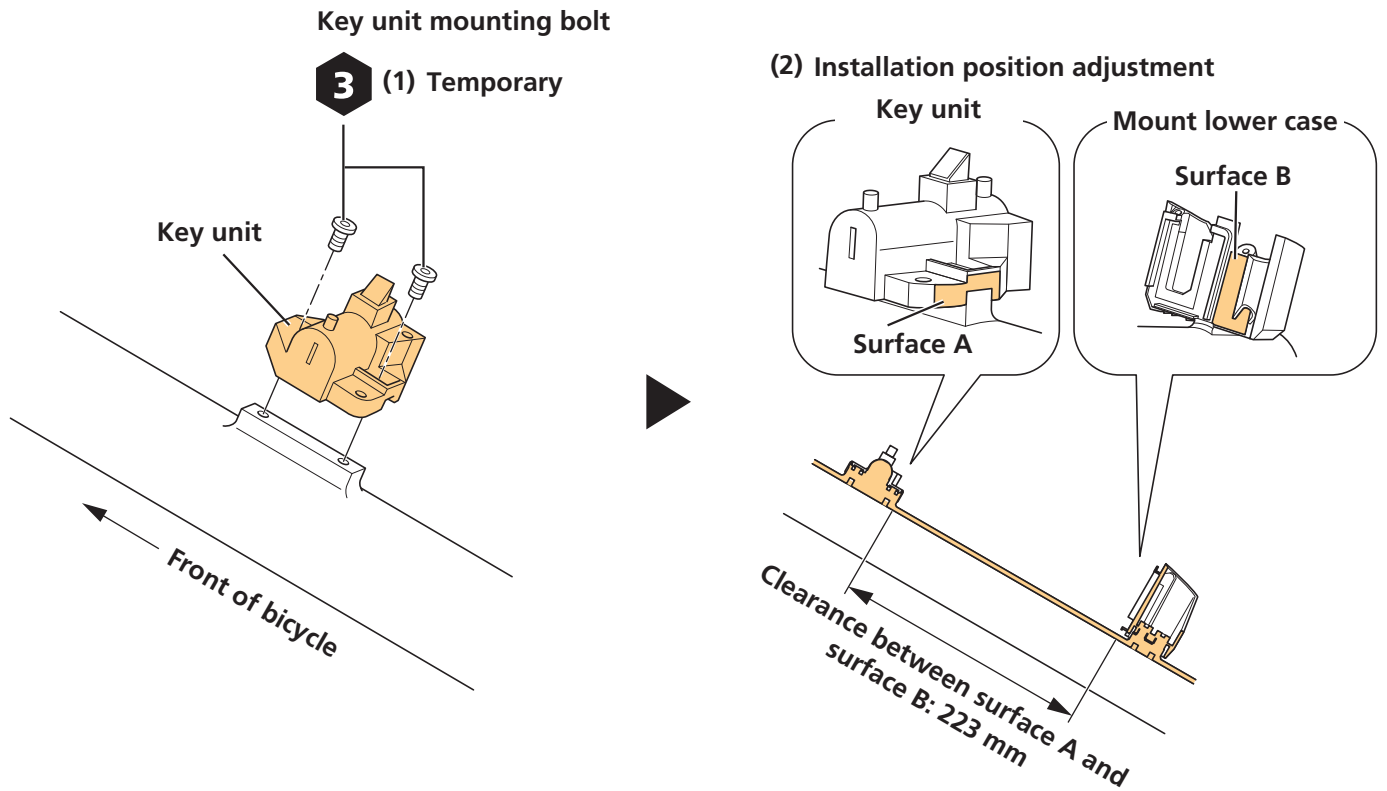

3. Secure the key unit.

(1) Temporarily install the key unit cover, and then check the following.

- The battery can be smoothly attached and removed
- There is no rattling in the key unit cover or battery that could result in abnormal noise when riding

(2) Remove the key unit cover, and then secure the key unit.

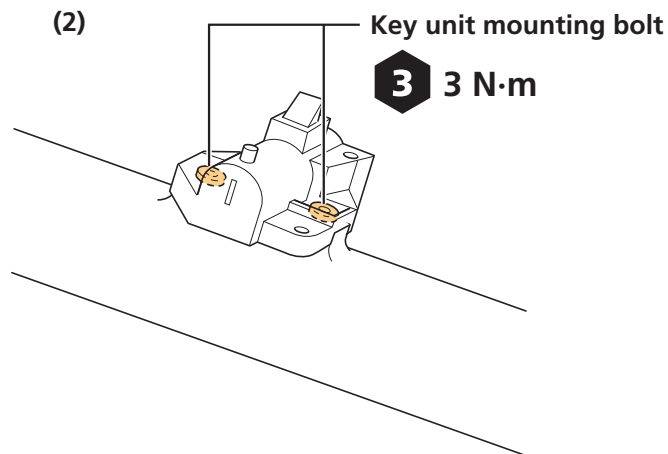
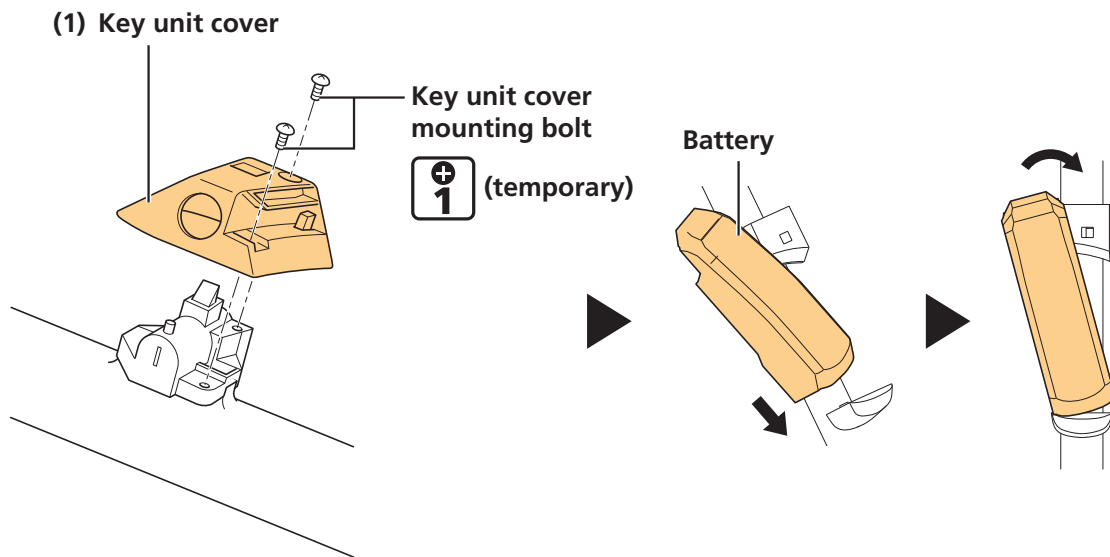

4. Install the key unit cover and the rattling prevention spacer.

- (1) Secure the key unit cover.
- (2) Peel the release liner on the back, and then attach the rattling prevention spacer to the key unit cover.

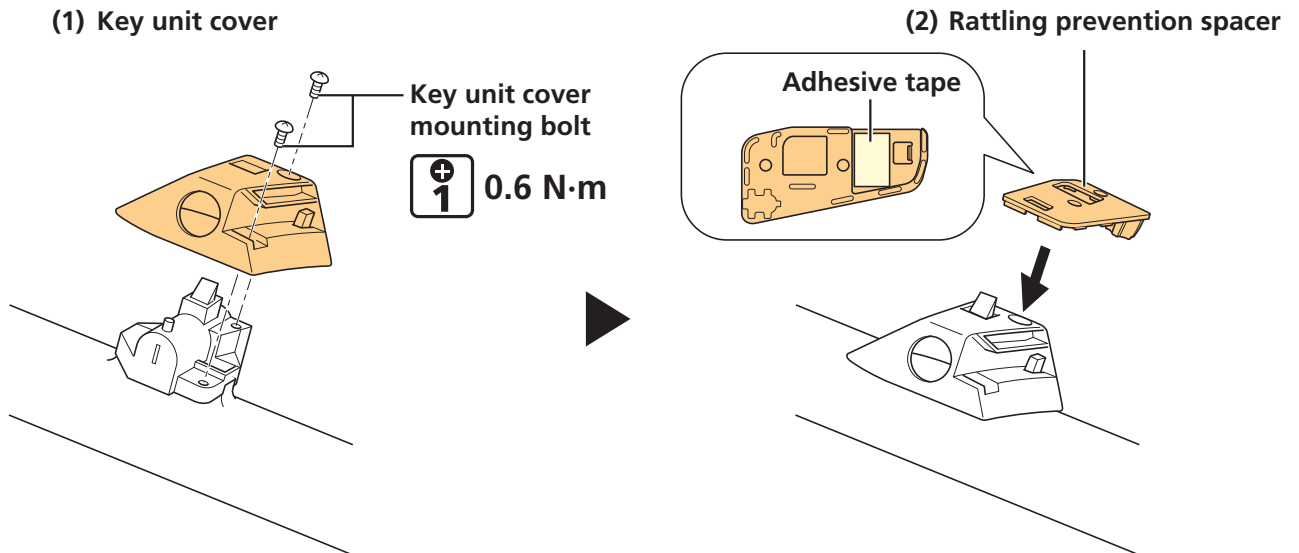

NOTICE

- Check that there is no oil or other foreign matter on the adhesive surface of the adhesive tape on the rattling prevention spacer or on the adhesion surface on the key unit cover. Remove any oil or other foreign matter before attaching.

5. Install the mount upper case.

- (1) Open the charging port cap and pull it out fully.
- (2) Insert the plug unit into the mount lower case. Make sure that the plug part of the plug unit and the charging port are sufficiently exposed from the mount lower case.
- (3) Align the two bolt holes on the mount upper case with the mount lower case, and then tighten the mount upper case mounting bolts.
- (4) After installing, perform the following.
 - Firmly close the charging port cap.
 - Pass the power cord through the frame and leave it hanging over the drive unit installation area.

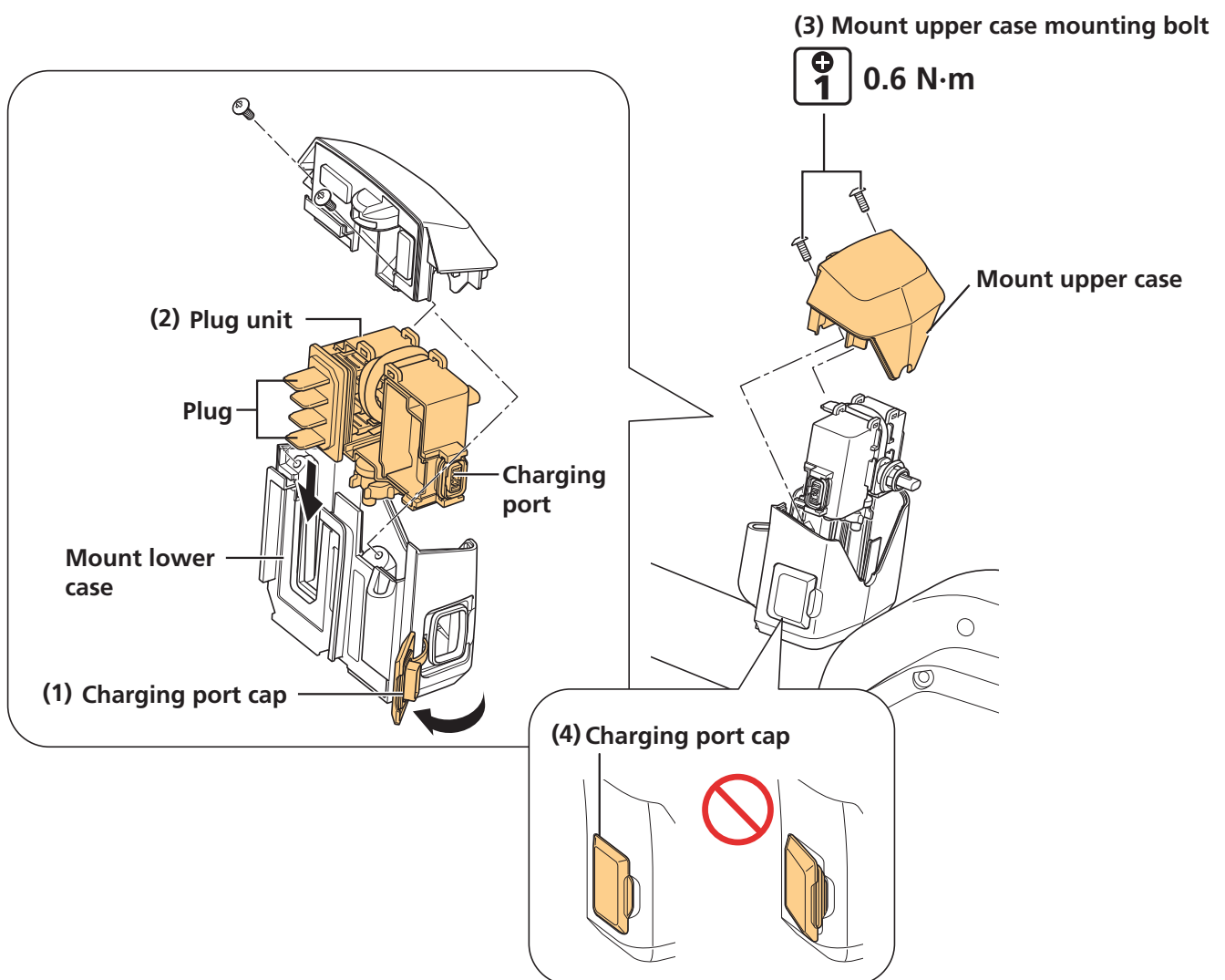

NOTICE

- Check that the power cord is not twisted between the mount upper case and mount lower case, or otherwise routed in a forced manner.

BM-E8010

1. Install the mount lower case.

(1) Set the mount lower case on the lower side of the down tube, and then temporarily install the mounting bolts.

* Temporarily install the two types of bolts as shown in the figure.

(2) Tighten mount lower case mounting bolt A.

(3) Tighten mount lower case mounting bolt B.

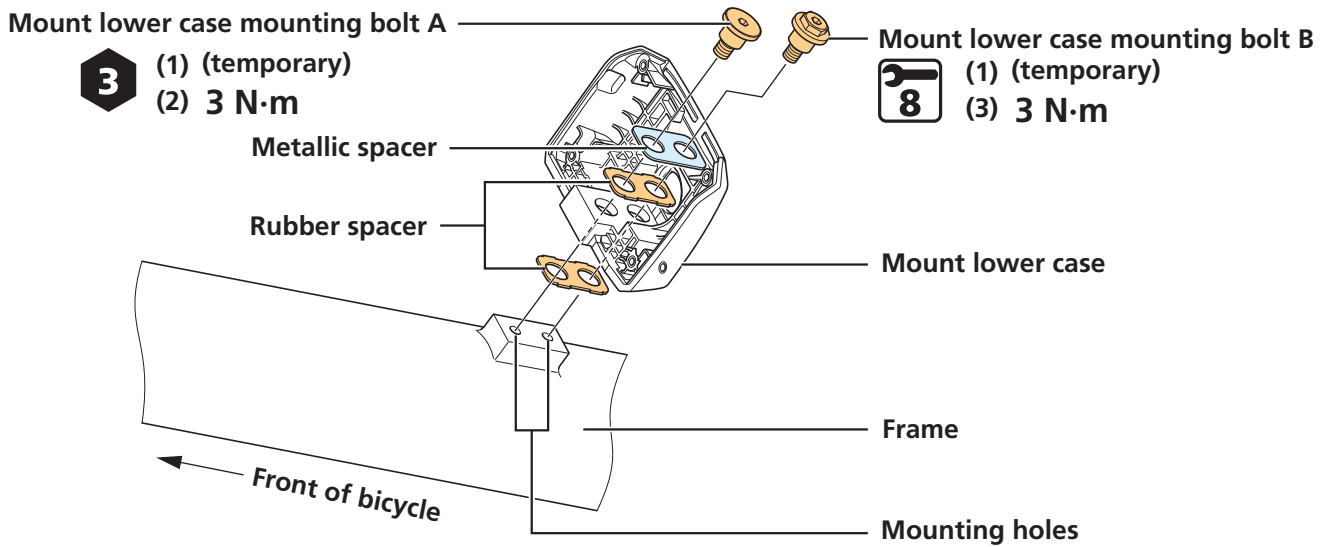

2. Install the key unit.

Key units are not included with SHIMANO products.

- (1) Temporarily install the key unit on the upper side of the down tube.
- (2) Adjust the key unit installation location.
- (3) Tighten the mounting bolt.

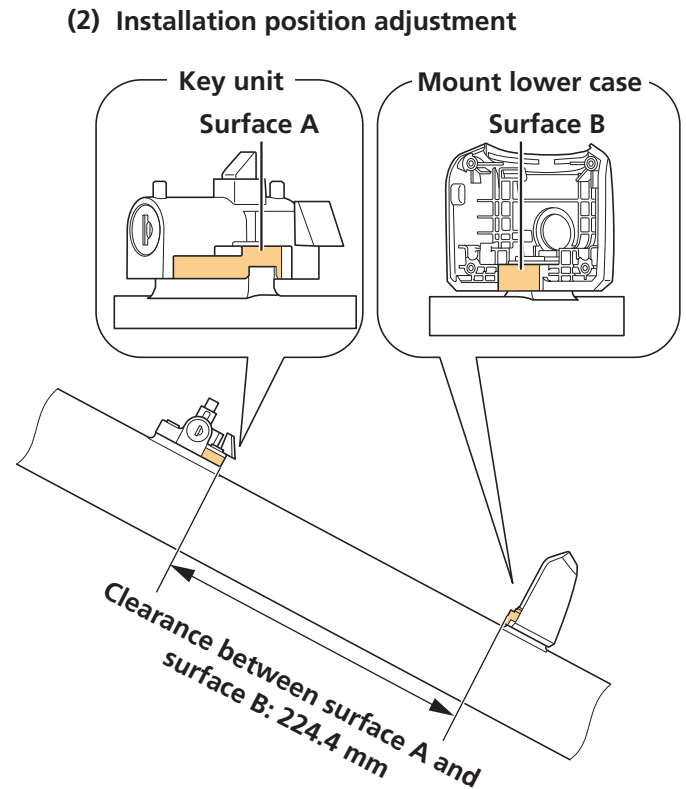
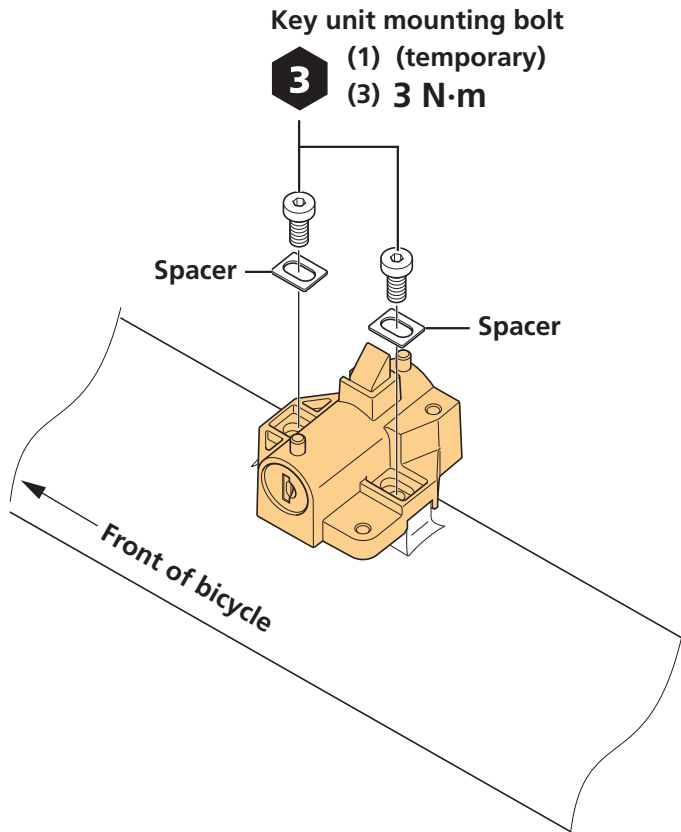

3. Install the key unit cover.

- (1) Temporarily install the key unit cover.
- (2) Try attaching and removing the battery, and check the following.
 - The battery can be smoothly attached and removed
 - There is no rattling in the key unit cover or battery that could result in abnormal noise when riding
- (3) Secure the key unit cover.

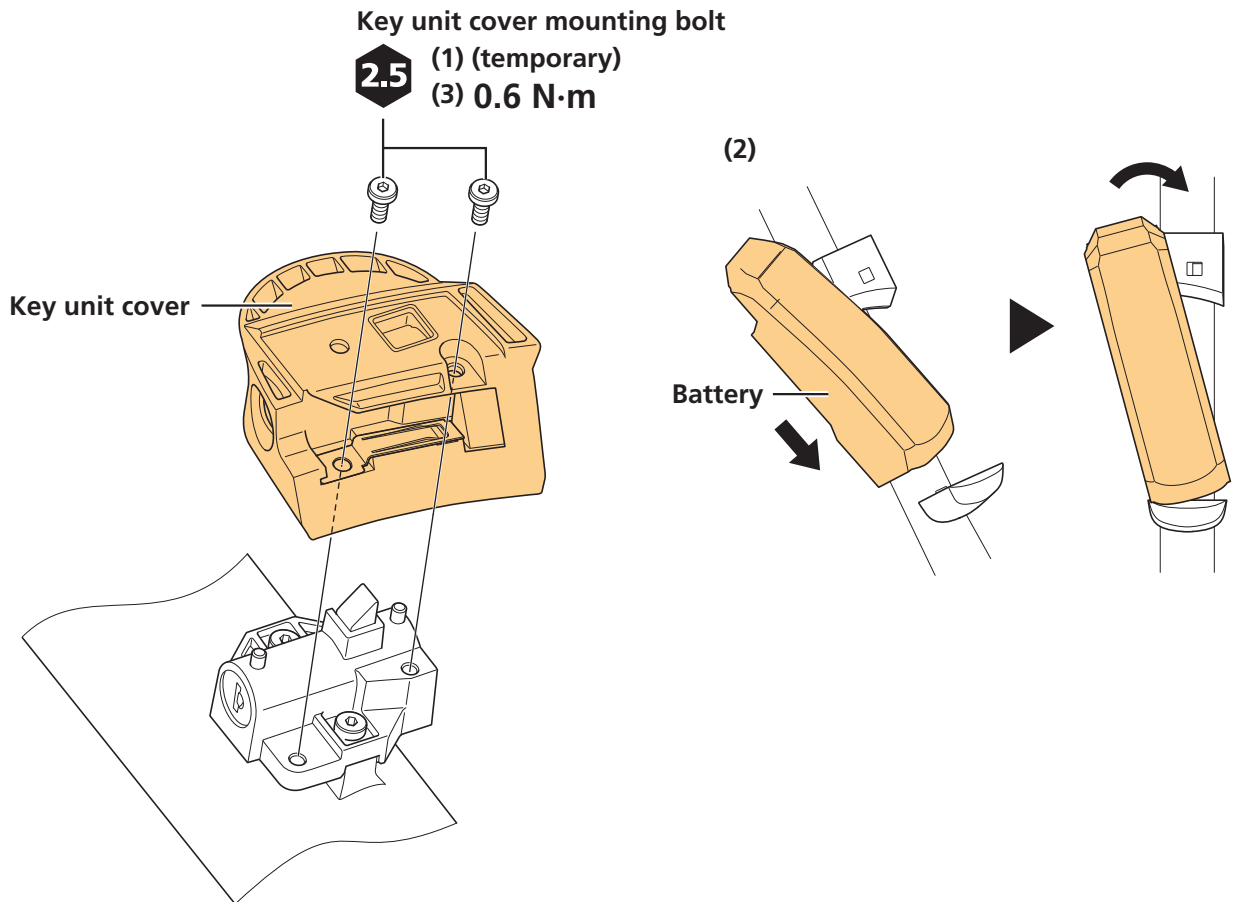

4. Install the mount upper case.

- (1) Pass the power cord from the mount upper case through the hole in the mount lower case.
- (2) Set the mount upper case to the mount lower case.
 - * Make sure that the rubber bush on the base of the power cord is exposed from below the mount lower case.
- (3) Secure the mount upper case.
- (4) Pass the power cord through the frame and leave it hanging over the drive unit installation area.

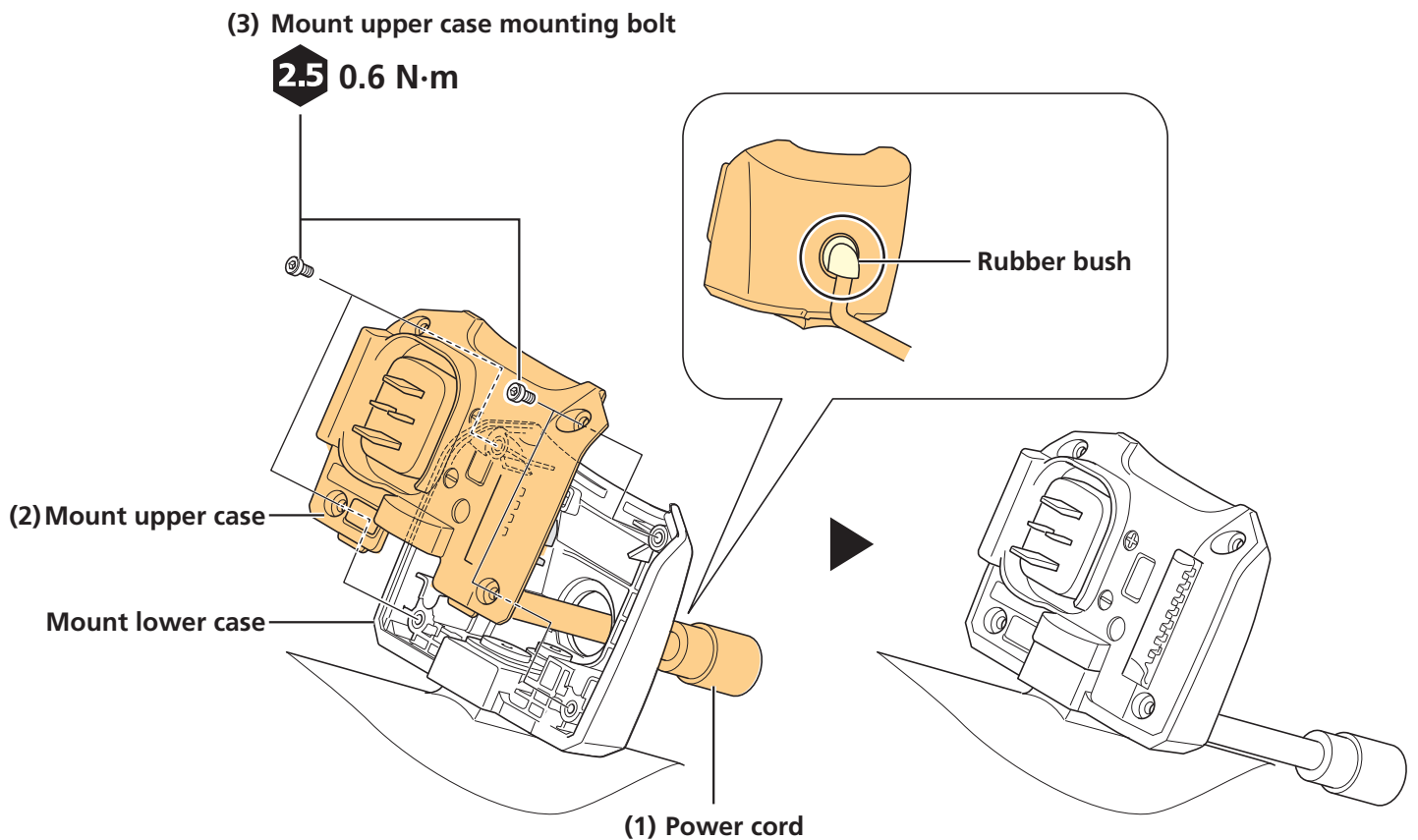

BM-E8020

If the following cables will be placed inside, pass them through first before installing BM-E8020.

- Electric wire
- Brake hose, brake cable, and shift cable

When installing BM-E8020 inside the frame, be careful that the cables listed above are not pinched.

1. Install the mount lower case to the frame.

- (1) Set so that any cables built into the down tube pass between the mount installation area on the frame.
- (2) Install the mount lower case on the lower side of the down tube.

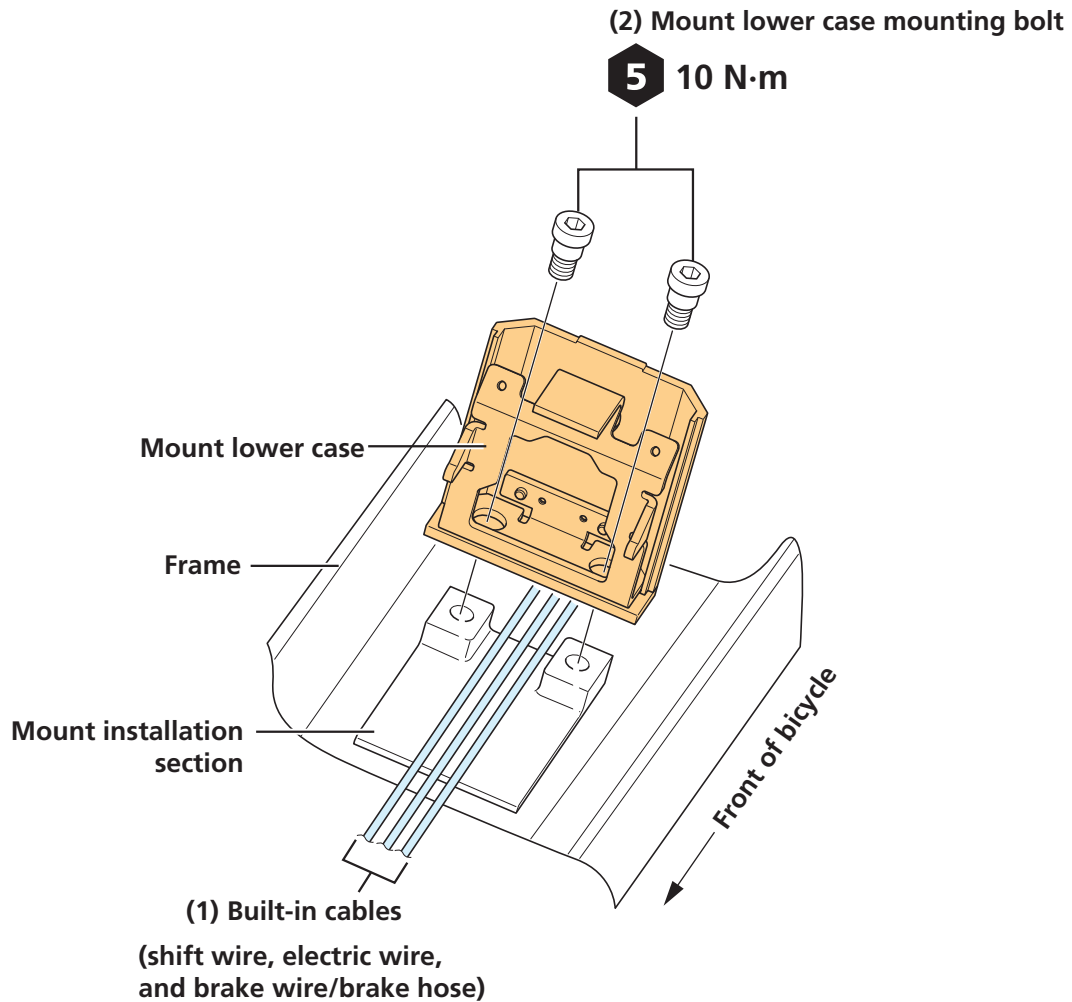

2. Install the mount upper case.

- (1) Pass the power cord from the mount upper case through the hole in the mount lower case.
- (2) Install the mount upper case to the mount lower case.

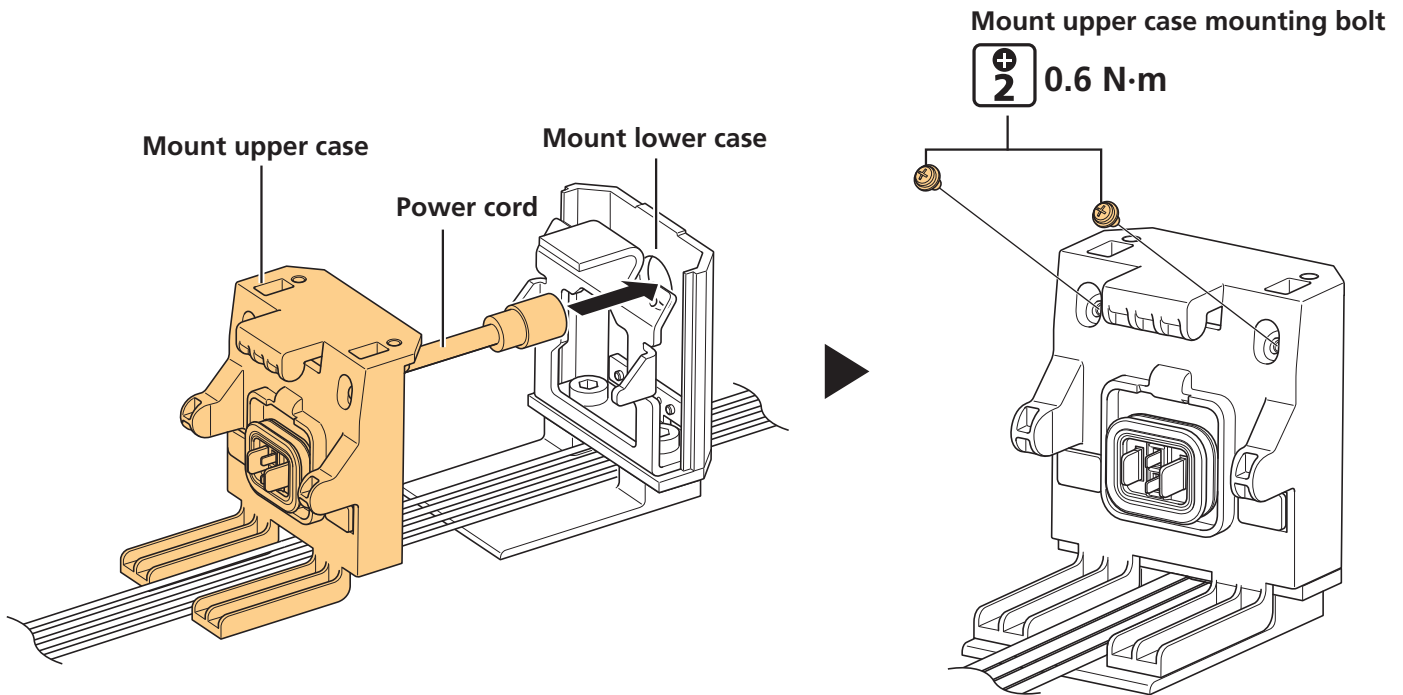

3. Install the cylinder to the key unit.

Key cylinders are not included with SHIMANO products.

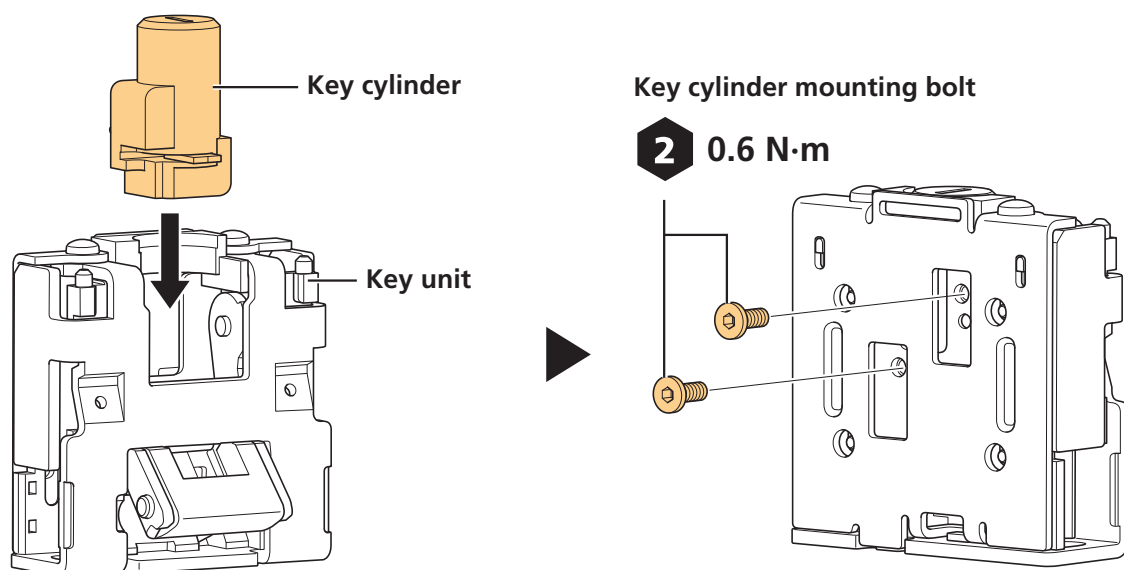

4. Install the key unit.

- (1) Make sure that any cables built into the down tube pass between the mount installation area on the frame.
- (2) Temporarily install the key unit on the upper side of the down tube, and then install the bolt detachment prevention rubber.
- (3) Adjust the key unit installation location.
- (4) Tighten the key unit mounting bolts.

Key unit mounting bolt

5

(2) (temporary)

(4) 10 N·m

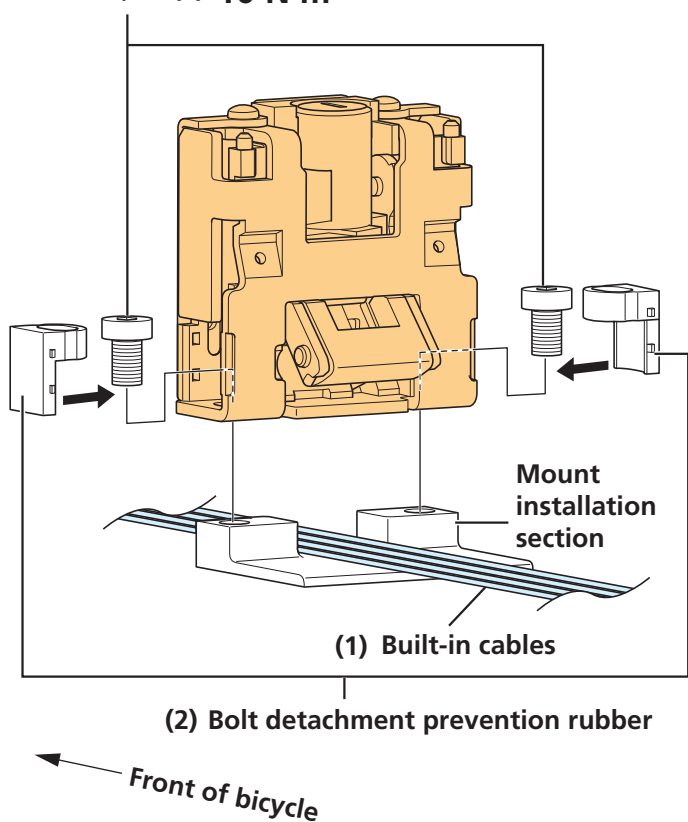

(3) Installation position adjustment

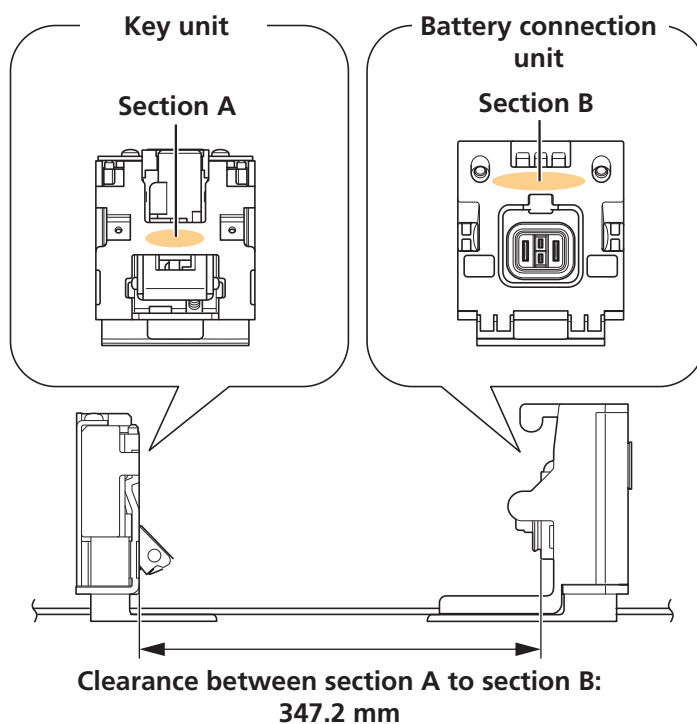

5. Install the key unit cover.

- (1) Temporarily install the key unit cover.
- (2) Try attaching and removing the battery, and check the following.
 - The battery can be smoothly attached and removed
 - There is no rattling in the key unit cover or battery that could result in abnormal noise when riding
- (3) Secure the key unit cover.
- (4) Pass the power cord through the frame and leave it hanging over the drive unit installation area.

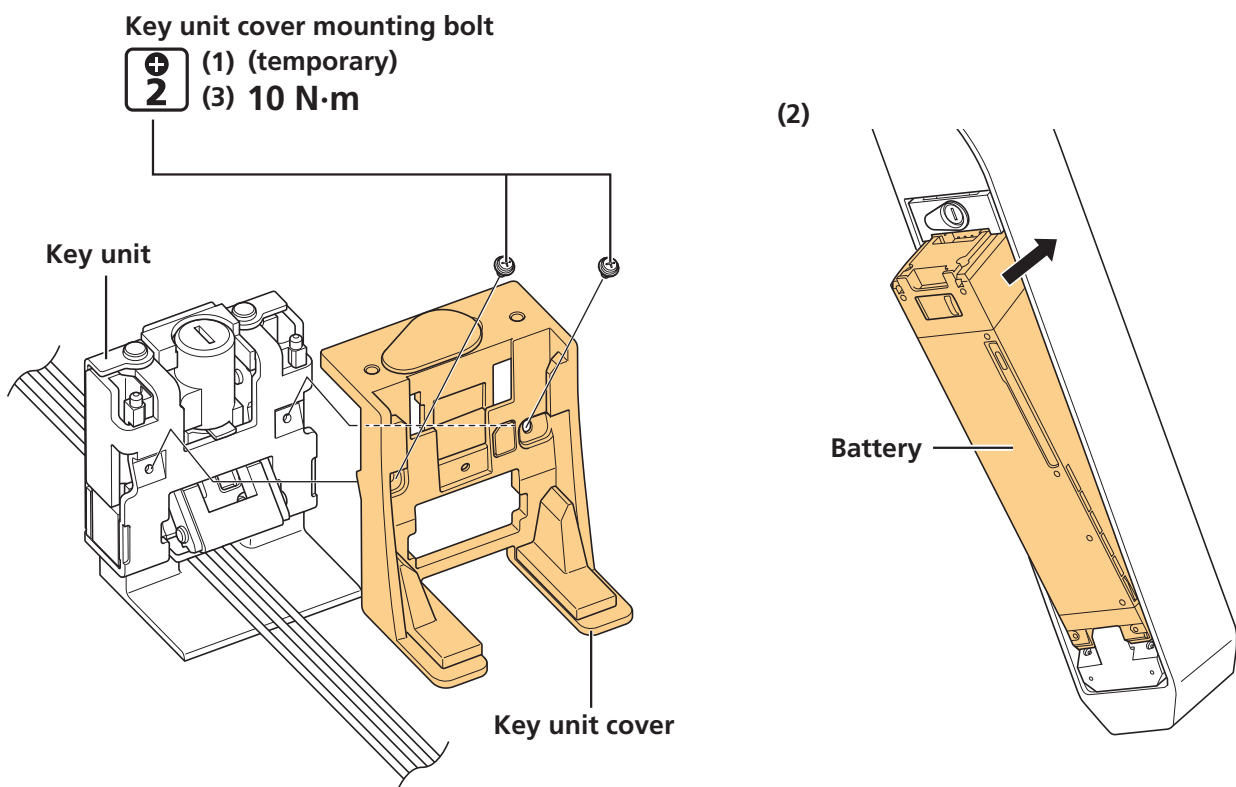

Installing the Speed Sensor and Magnet Unit

SM-DUE10

If using SM-DUE10 as the speed sensor, set the magnet unit on a spoke on the rear wheel. The SM-DUE10 installation location is on the inner side of the left side chainstay.

1. Temporarily install the magnet unit to the spoke.

- (1) Try pressing the speed sensor to the installation location on the frame, and determine the installation location of the magnet so that the center of the magnet is aligned over the tip of the triangle symbol.
- (2) Temporarily install the mounting bolt.

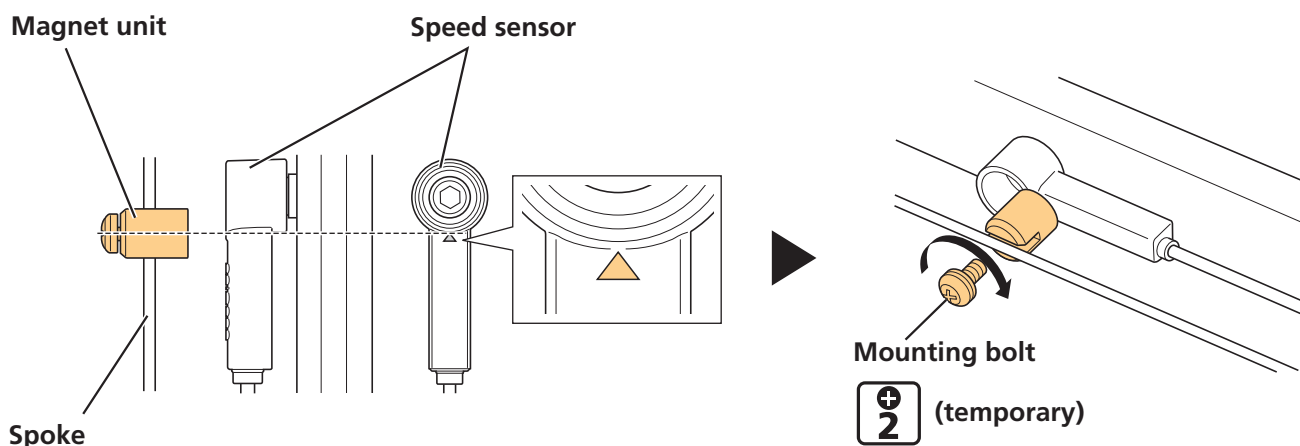

2. Check the clearance between the speed sensor and magnet unit.

Press the speed sensor to the installation location on the frame, and then check the approximate clearance with the magnet unit. Also take wheel play and frame warping into consideration.

Clearance between speed sensor and magnet unit

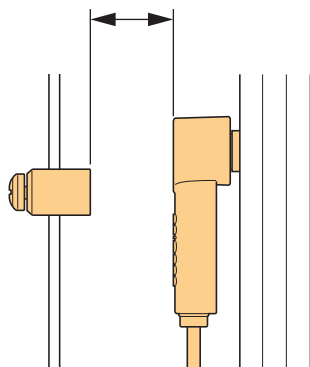

3. Install the speed sensor.

Clearance between speed sensor and magnet unit is 3 to 17 mm

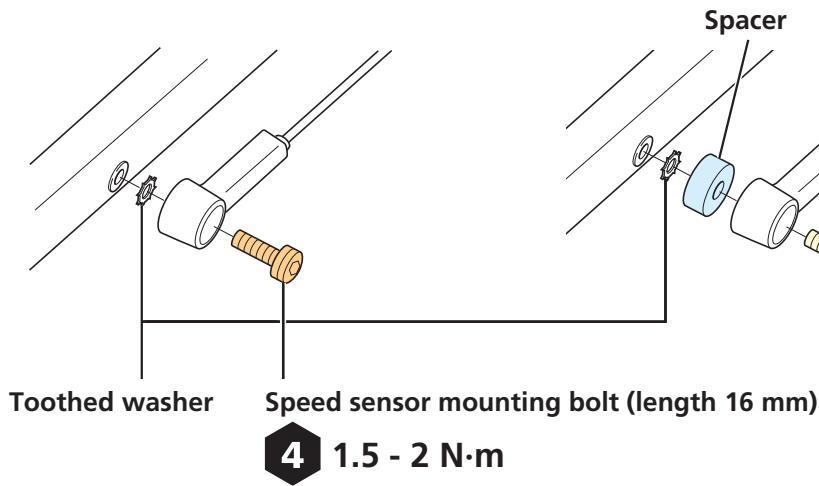

Clearance between speed sensor and magnet unit exceeds 17 mm

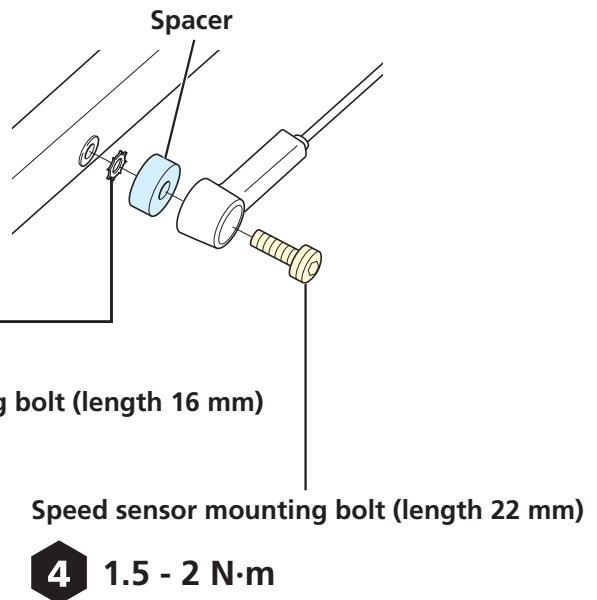

4. Secure the magnet unit.

- (1) Re-check the positioning of the magnet unit and speed sensor.
- (2) Secure the magnet unit.

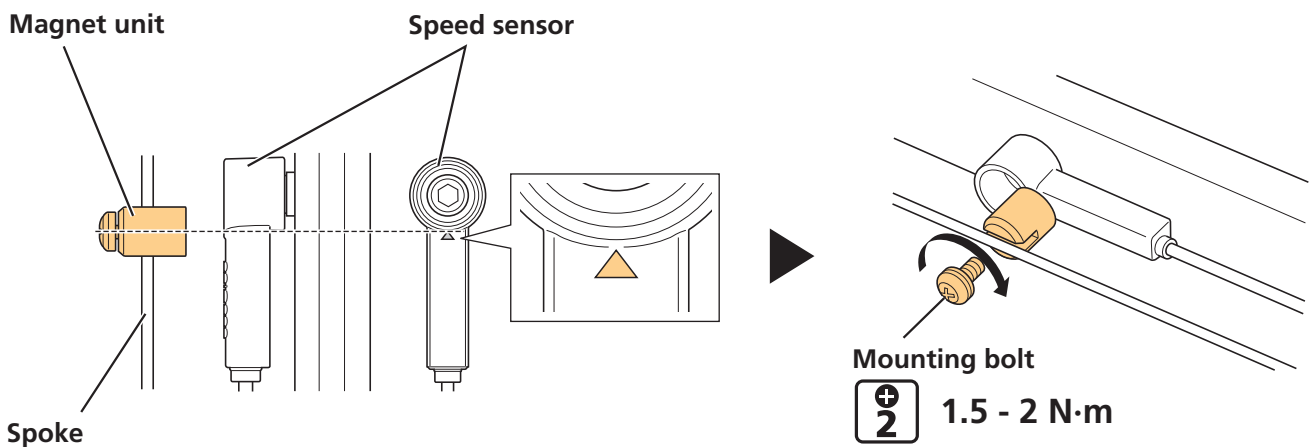

5. Set the electric wire from the speed sensor along the chainstay to the frame, and wire it to the drive unit.

SM-DUE11

If using SM-DUE11 as the speed sensor, a special disc brake rotor with a built-in magnet must be installed to the rear wheel. The SM-DUE11 installation location is near the rear wheel axle on the inside of the left side chainstay.

1. Check that the spokes on the rear wheel have been laced as shown in the figure.

A disc brake rotor cannot be installed to a wheel with radial lacing.

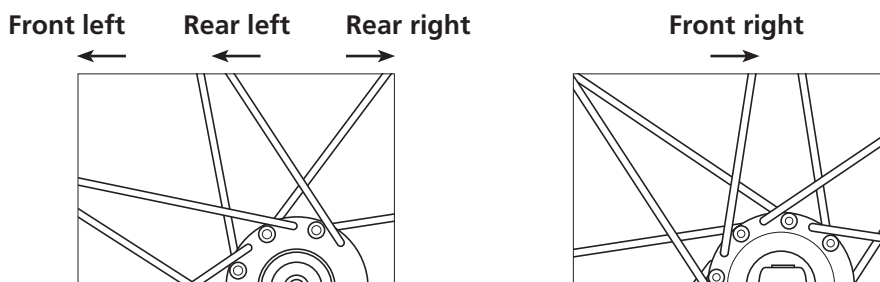

2. Install the disc brake rotor.

- (1) Set the disc brake rotor to the hub on the rear wheel.
- (2) Tighten the disc brake rotor fixing lock ring.

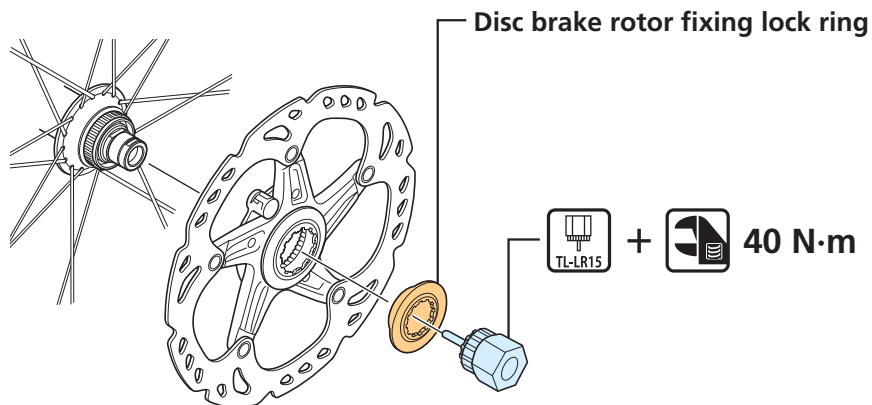

3. Install the speed sensor to the frame.

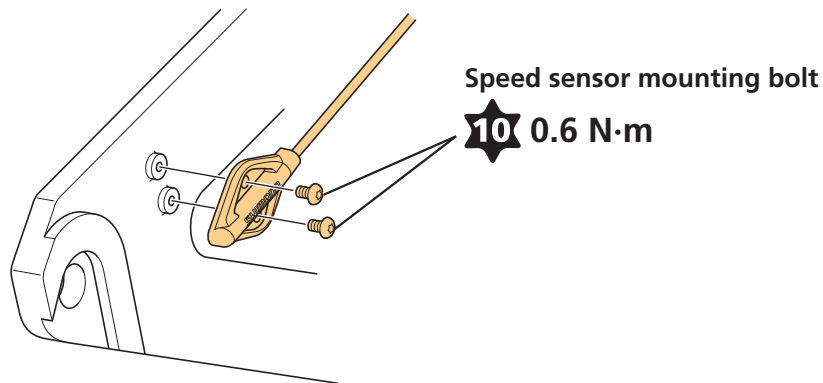

4. Set the electric wire from the speed sensor along the chainstay to the frame, and wire it to the drive unit.

5. Set the rear wheel to the frame.

INSTALLING THE DRIVE UNIT AND PERIPHERAL PARTS

Use the following procedure to install the drive unit and peripheral parts.

- (1) Installing the drive unit
- (2) Wiring to the drive unit
- (3) Installing the drive unit cover
- (4) Install the chainrings and crank arms

TECH TIPS

- To check the wiring of the drive unit on a completed bicycle, you will need to first remove the drive unit cover. Remove the right cover (front side) to access the power cord and terminal block.

Installing the Drive Unit

Before installing the drive unit to the frame, first check that all electric wires and cables to connect to the drive unit have been routed to the installation area of the drive unit.

TECH TIPS

- The drive unit's (DU-E6100) terminal block and power port are located on the right side of the drive unit.

1. Check the three mounting holes on the left and right of the frame, and then set the drive unit.

Be careful not to pinch electric wires or cables between the frame and drive unit, or to forcefully bend them.

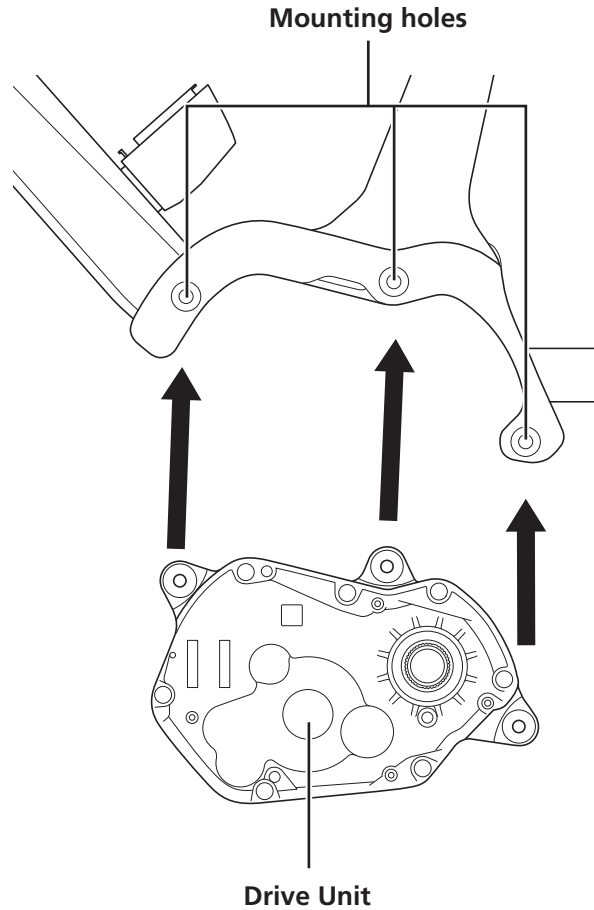

2. Secure the drive unit to the frame.

- (1) Temporarily install the drive unit mounting bolts first on the right side of the frame, and then on the left side.
- (2) Tighten the mounting bolt on the right side so that the drive unit makes firm contact with the inner surface on the right side of the frame.
- (3) Tighten the mounting bolt on the left side of the frame.

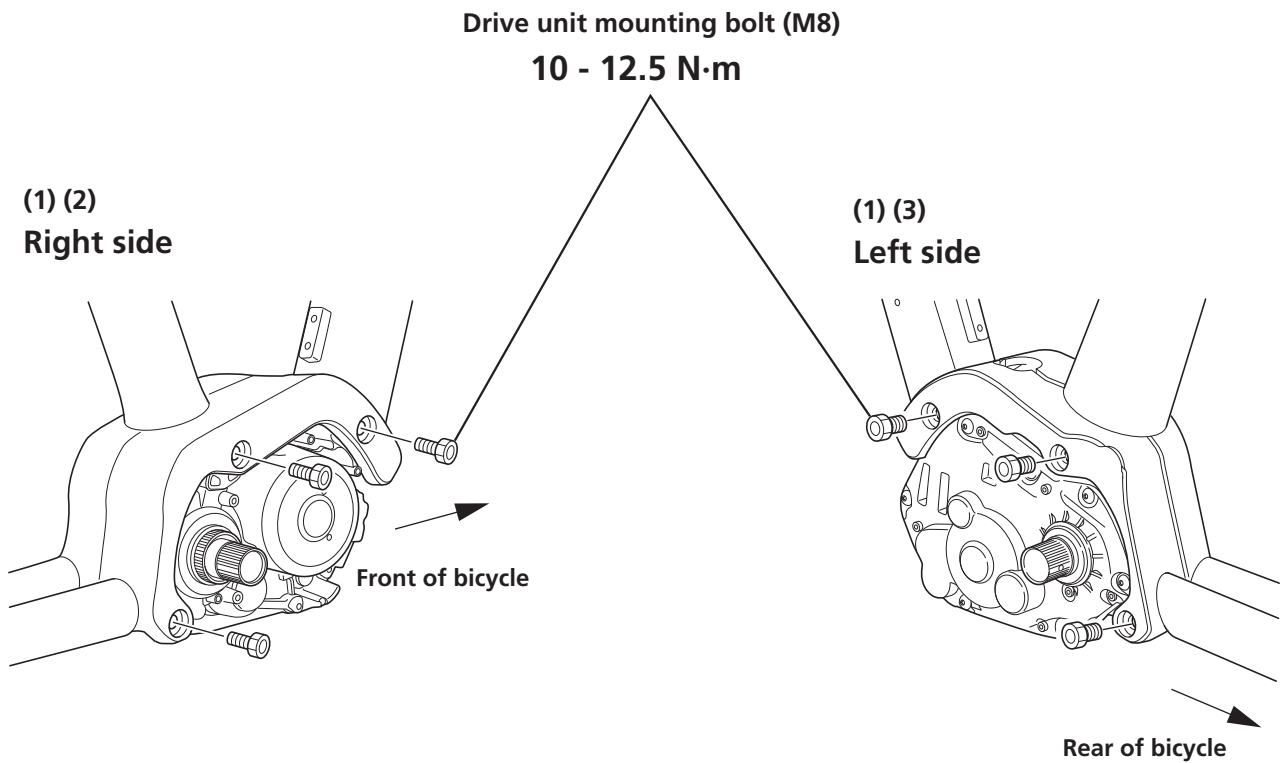

TECH TIPS

- Drive unit mounting bolts (M8) are not included with SHIMANO products. Use the bolts supplied by the bicycle manufacturer.

Connecting the Power Cord

Connect the power cord (which has already been routed from the battery mount toward the drive unit) to the power port on the drive unit. The power port is located toward the bottom on the front of the right side of the drive unit.

Connection method

1. Connect the power cord.

- (1) The arrow marking on the tip of the power cord faces the bottom.
 - (2) Align the triangle marking on the drive unit's power port with the arrow marking on the tip of the power cord, and then insert the power cord.
- * Check that it is securely connected.

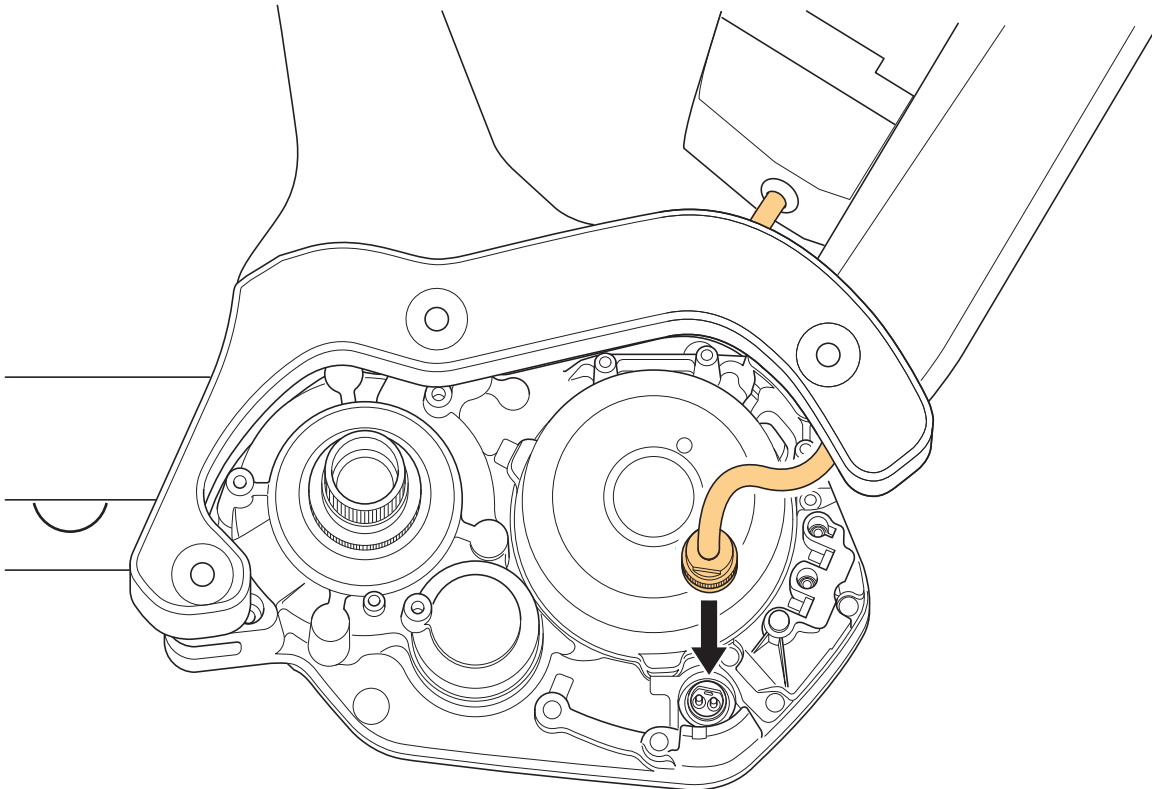

Removal method

1. Remove the power cord.

Grab the groove on the plug part of the power cord, and pull it toward you to remove it.

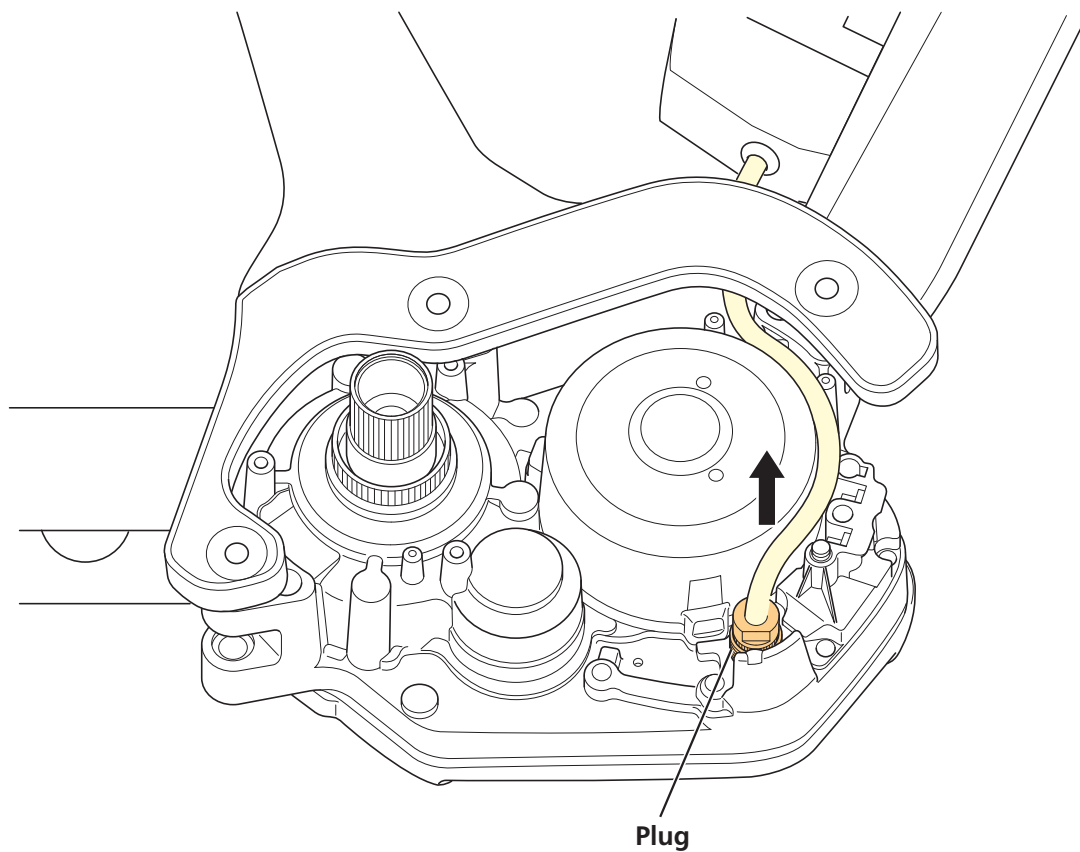

Connecting Cockpit Peripheral Parts and Electronic Gear Shifting Components

Connect wires from the cockpit peripheral parts (such as the cycle computer and junction [A]) and (wires) from electronic gear shifting components to the drive unit's terminal block.

1. Connect the electric wires to the drive unit's terminal block.

- The two E-TUBE ports on the bottom of the terminal block can be used.
- Connect the wire from either the cycle computer or junction [A] to one, and the wire from the electronic gear shifting component (rear derailleur or motor unit) to the other.

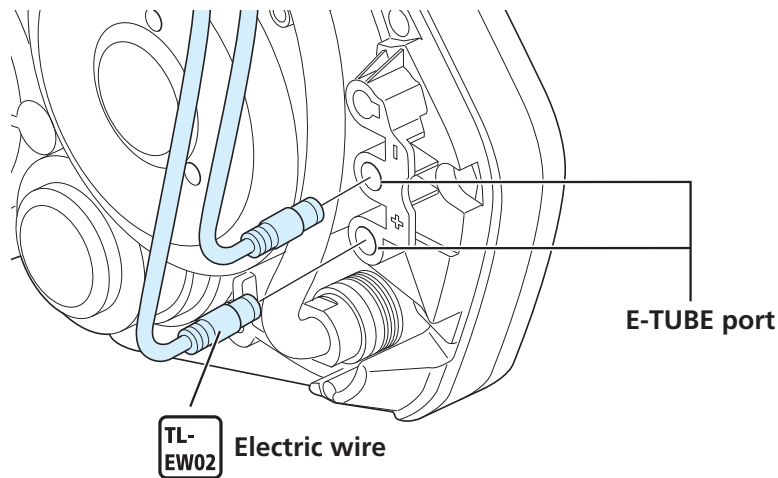

NOTICE

- Be sure to attach dummy plugs to any unused E-TUBE ports.

Connecting the Speed Sensor

Connect the speed sensor's electric wire to the drive unit's terminal block.

1. Connect the electric wire to the drive unit's terminal block.

Use the topmost speed sensor port on the terminal block.

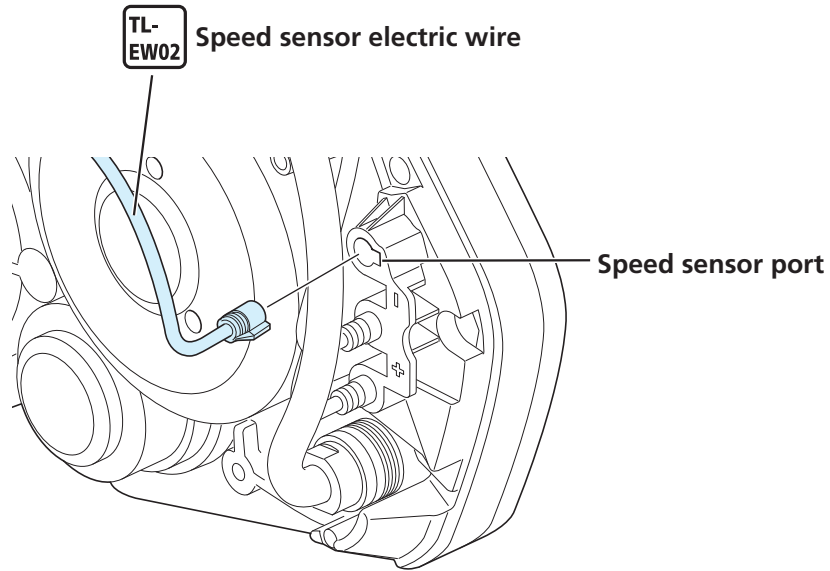

Connecting the Light Cables

The drive unit contains terminals to supply power for the front and rear lights. Connect the wires connected to the front and rear lights (that have already been passed through the frame) to the drive unit.

1. Loosen the mounting bolts on the terminal block.

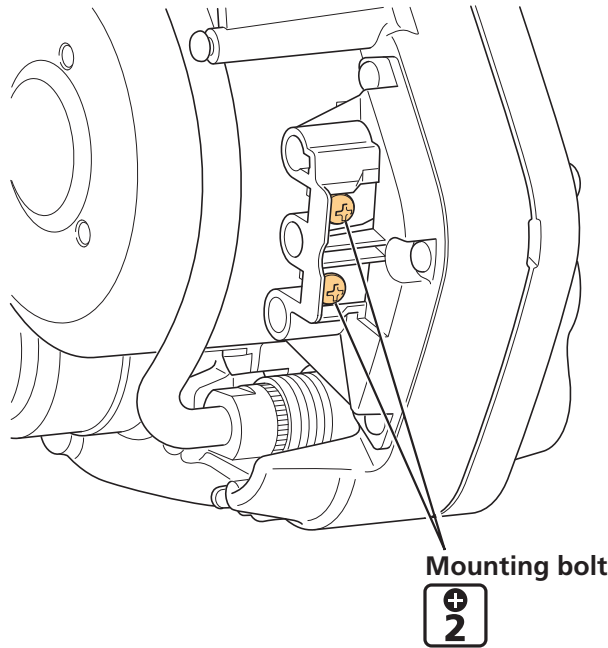

2. Connect the light cables to the light connection terminals, and then tighten the mounting bolts.

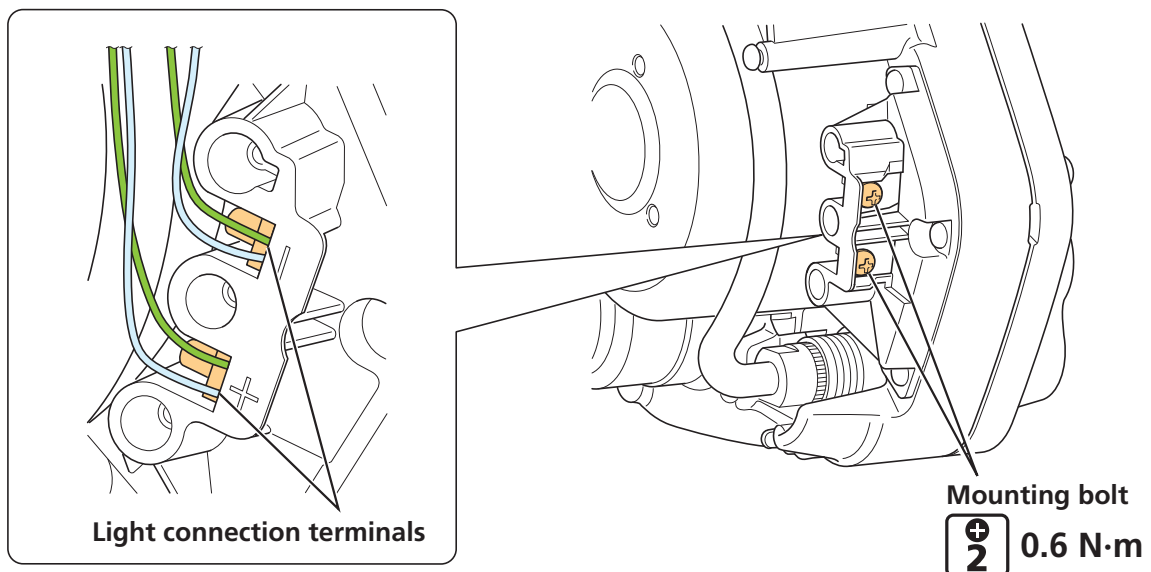

Installing the Drive Unit Cover

This can involve either the single use of a SHIMANO drive unit cover or combined use with a drive unit cover from another company.

SHIMANO drive unit cover only

This section explains how to install SM-DUE61-T or SM-DUE61-C. Although the appearance varies by model, the example shown here is for SM-DUE61-T.

1. Install the left cover.

- (1) Set the left cover to the drive unit from below the bicycle.
- (2) Secure the left cover using the three cover mounting bolts.

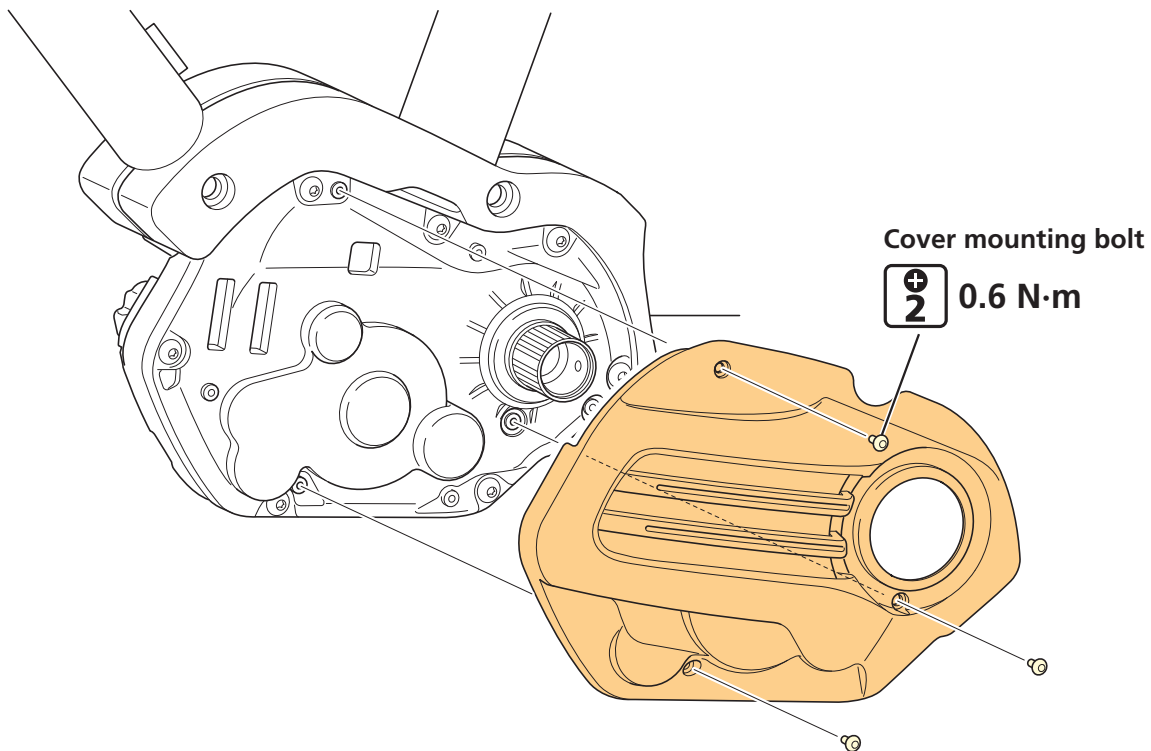

2. Install the right cover (rear side).

- (1) Set the right cover (rear side) to the drive unit from below the bicycle.
- (2) Secure the right cover (rear side) using the three cover mounting bolts.

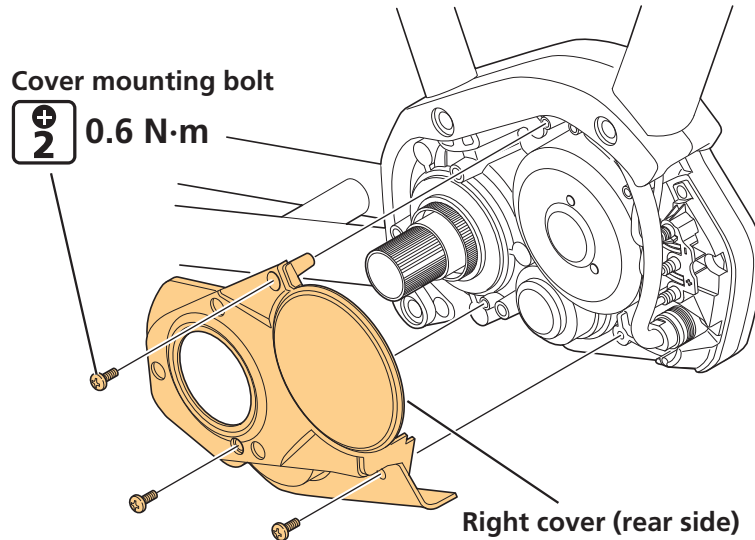

3. Install the right cover (front side).

- (1) Set the right cover (front side) to the drive unit from below the bicycle.
- (2) Secure the right cover (front side) using the three cover mounting bolts.

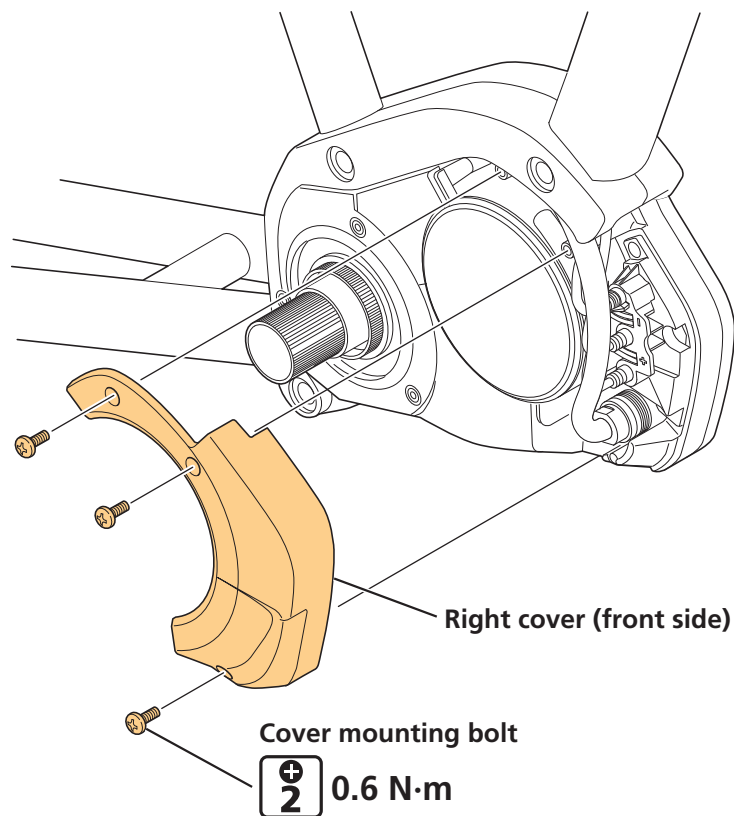

Used with drive unit cover from other company

This section explains how to install SM-DUE61-TC or SM-DUE61-CC. Although the appearance varies by model, the example shown here is for SM-DUE61-TC.

Always install a drive unit cover from another company after installing the SHIMANO drive unit cover.

1. Install the left cover.

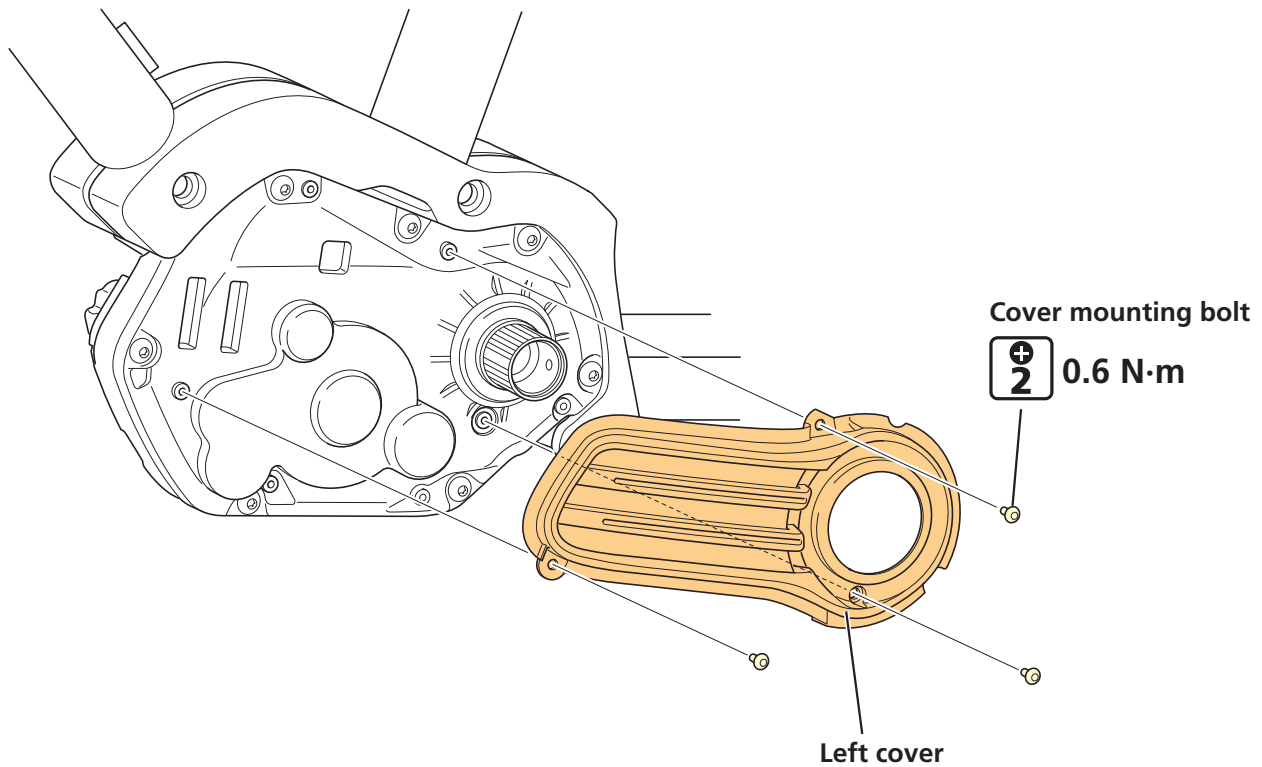

2. Install the right cover.

- (1) Peel the release liner from the right cover.
- (2) Align the positions of the convex section on the rear of the right cover and the concave section on the drive unit, and then attach the right cover to the drive unit.

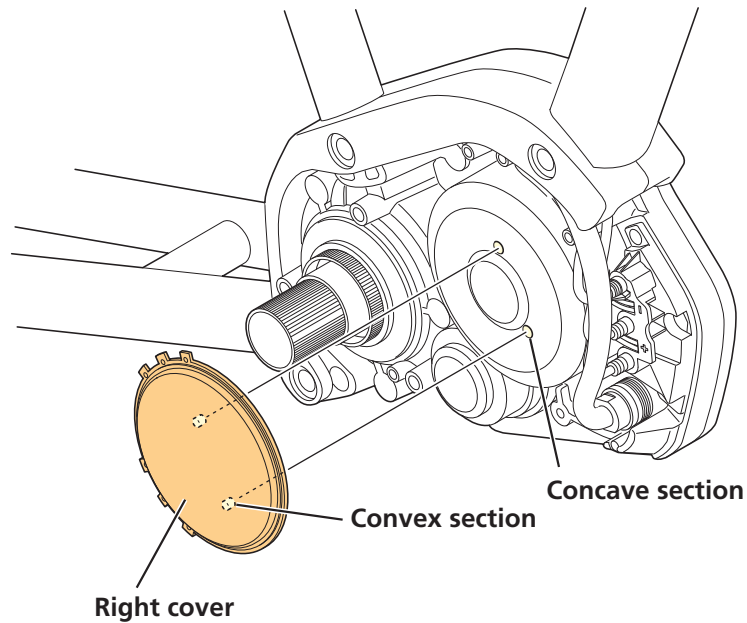

NOTICE

- Check that there is no oil or other foreign matter on the adhesive surface of the adhesive tape on the right cover or on the adhesion surface on the drive unit. Remove any oil or other foreign matter before attaching.

Installing the Front Chainring and Crank Arms

In SHIMANO STEPS, there is a crank axle in the drive unit. Because of this, the front chainring and left/right crank arms should be installed individually to the drive unit. Set the rear wheel to the bicycle prior to performing the following procedure.

1. Set the left crank arm.

- (1) The left crank arm has an "L" marking on one end (the side where the pedal is installed).
- (2) Check that the stopper plate on the left crank arm is exposed.
- (3) Set the left crank arm with the wide part of the spline on the left crank arm aligned with the wide part of the spline on the crank axle.
- (4) Tighten the cap.

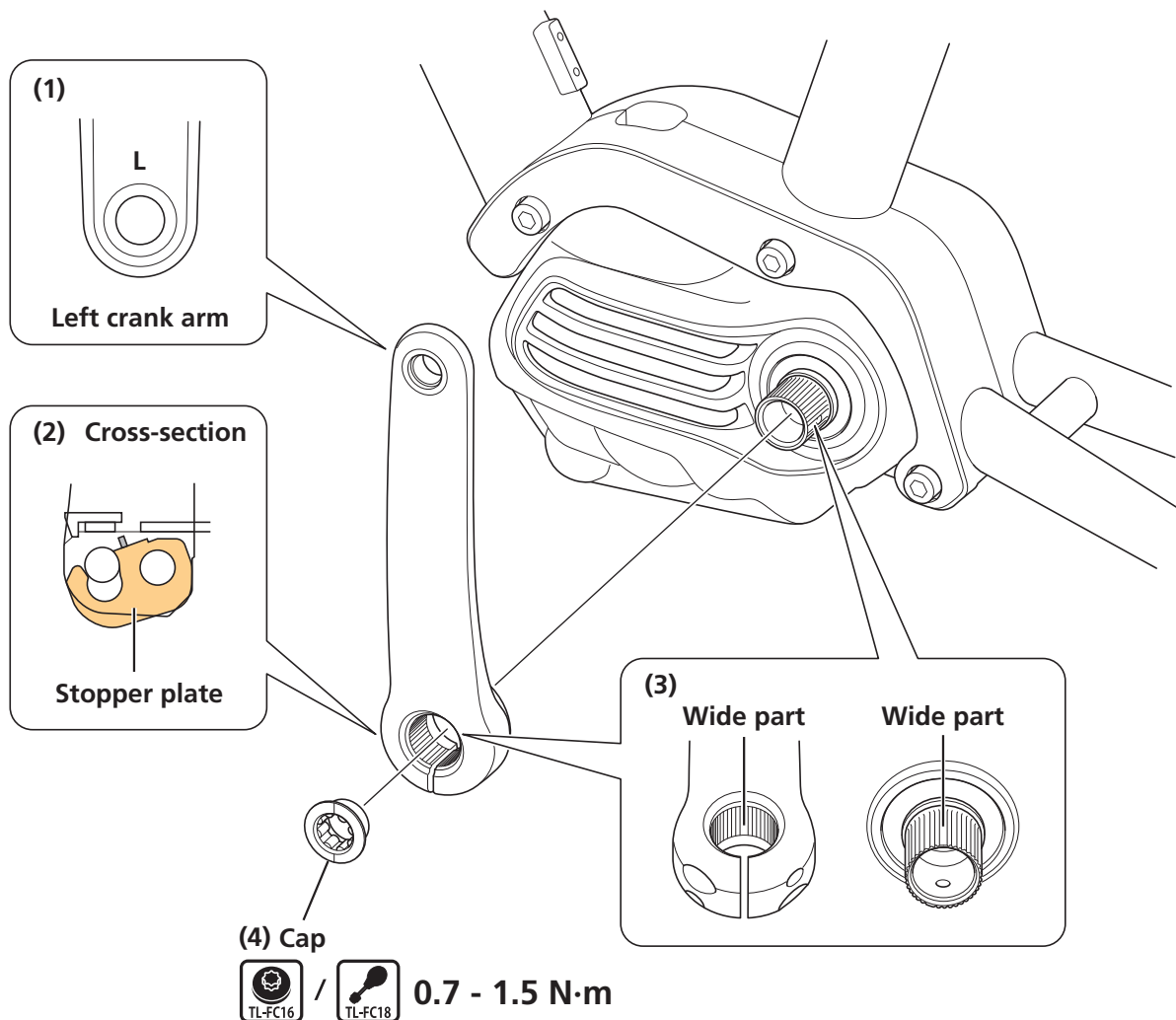

2. Secure the left crank arm.

(1) Press the stopper plate in.

* Check that the plate pin is firmly set.

(2) Tighten the two clamp bolts alternately.

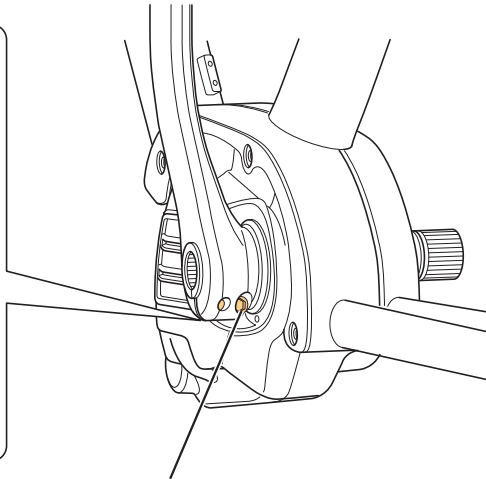
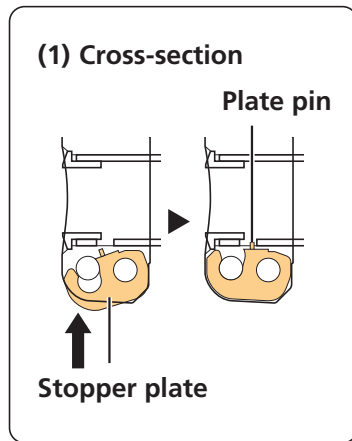

5 12 - 14 N·m

NOTICE

- Set the stopper plate in the correct direction as shown in illustration. For the left crank arm, the figure depicts the part as looking from the back of the bicycle.

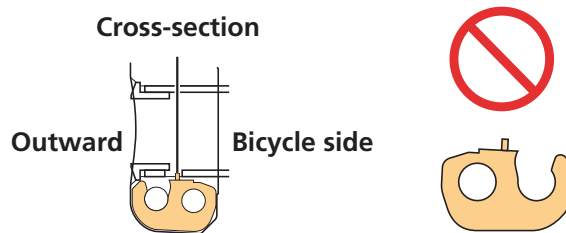

3. Set the chainring.

Set with the spline on the chainring aligned with the chainring installation spline on the crank axle.

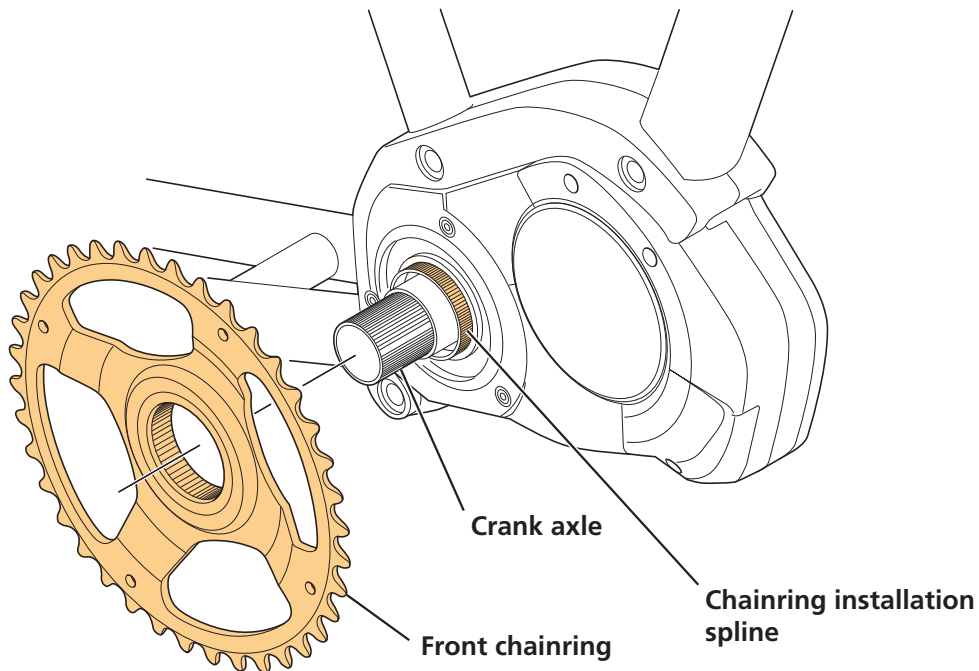

TECH TIPS

- There are three types of front chainrings: those with a chain guard on both the front and rear sides, those with a chain guard only on the outside, and those with no chain guard. The explanation in this section uses one without a chain guard.

4. Set the chain.

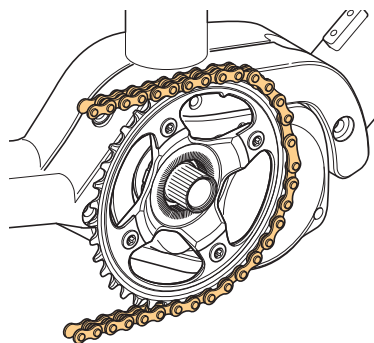

5. Secure the chainring.

- (1) Prepare the SHIMANO original tool.
- (2) Install the lock ring (left screw) by hand.
- (3) Use the SHIMANO original tool to tighten the lock ring while firmly pressing the left crank.

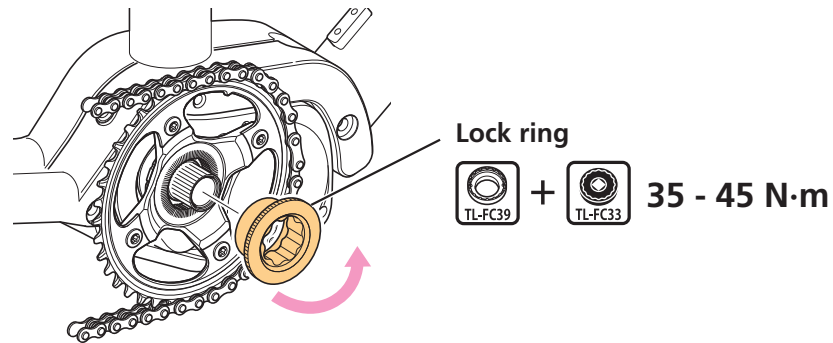

TECH TIPS

- An impact wrench cannot be used.

6. Set the right crank arm.

- (1) The right crank arm has an "R" marking on one end (the side where the pedal is installed).
- (2) As with the left crank arm, set the right crank arm and tighten the cap.

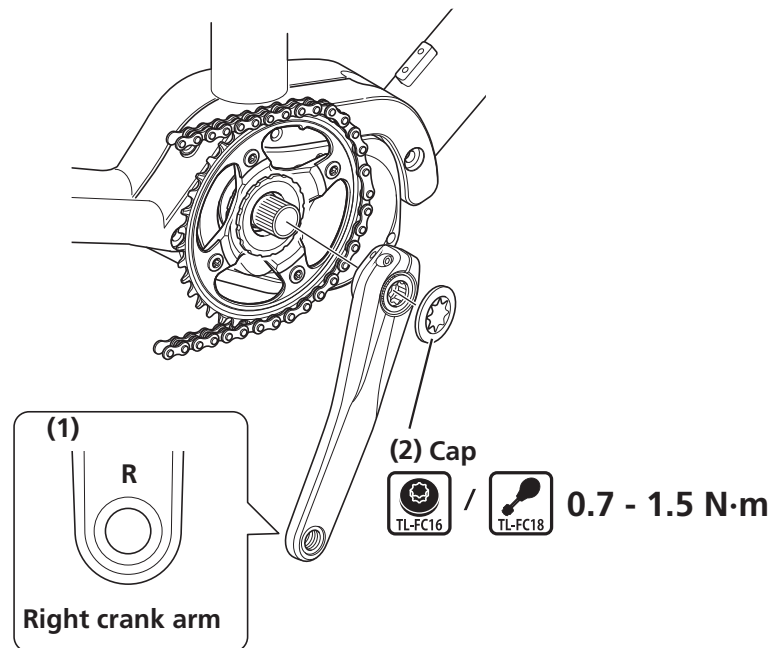

7. Secure the right crank arm.

(1) Press the stopper plate in.

* Check that the plate pin is firmly set.

(2) Tighten the clamp bolt.

* For a chainring without a chain guard, proceed to the next section ("Installing the Arm Covers").

* For internal geared hub models, proceed to "Measuring and Adjusting the Chain Tension."

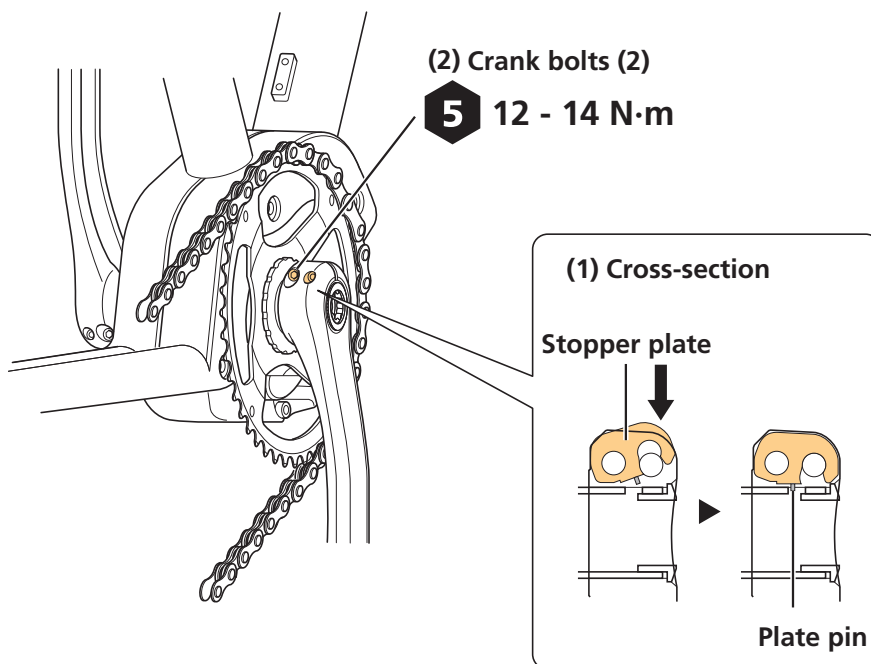

NOTICE

- Set the stopper plate in the correct direction as shown in illustration.

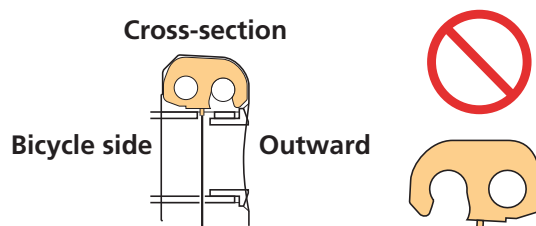

Installing the Arm Covers

If the chainring has no chain guard, install the arm covers after installing the chainring to the drive unit.

1. Set the arm covers to the left and right sides of the chainring.

Install so that the hooks catch the spider arm on the chainring.

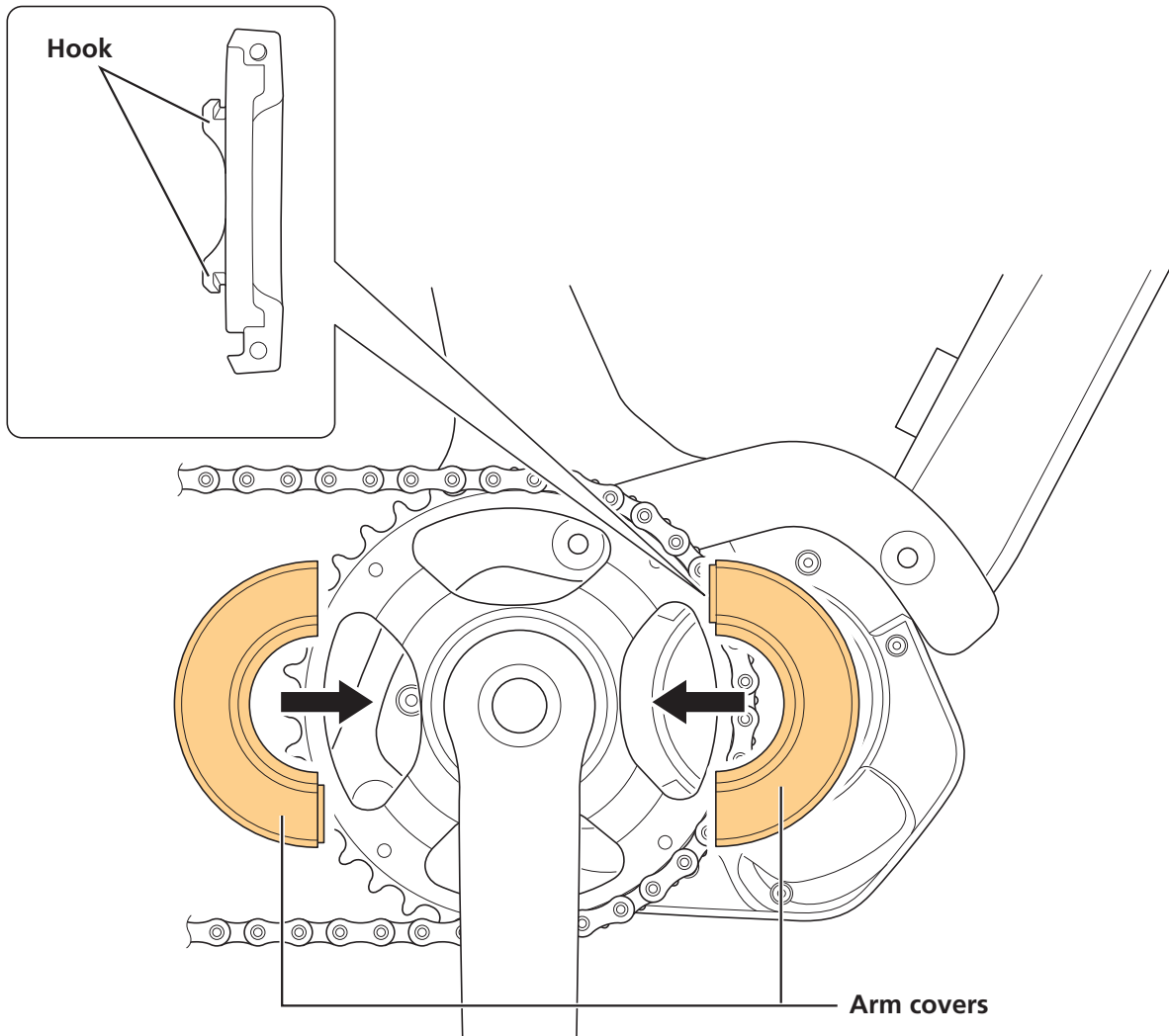

2. Tighten the two mounting bolts from the left and right.

For internal geared hub models, proceed to the next section ("Measuring and Adjusting the Chain Tension").

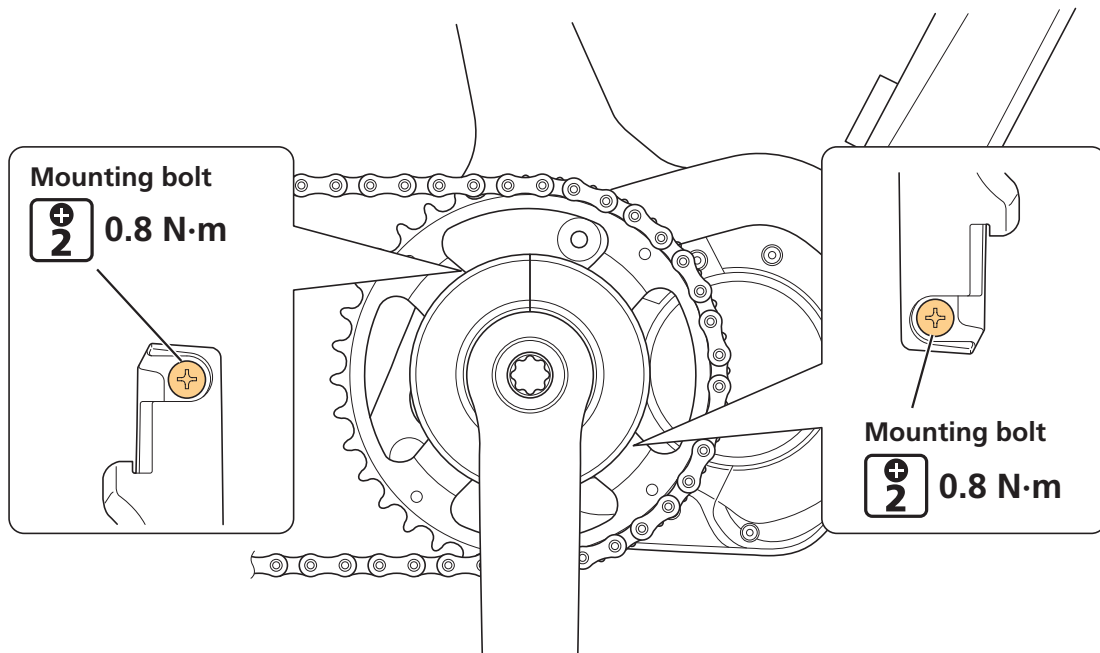

Measuring and Adjusting the Chain Tension

The chain tension must be adjusted for internal geared hub models.

Manual adjustment

1. Check and adjust the chain tension.

Pull the upper side of the chain up and down with a force of around 10 N (1 kgf), roughly in the middle between the crank axle and wheel axle. Adjust the chain tension so that the chain has a slack of 15 mm or less.

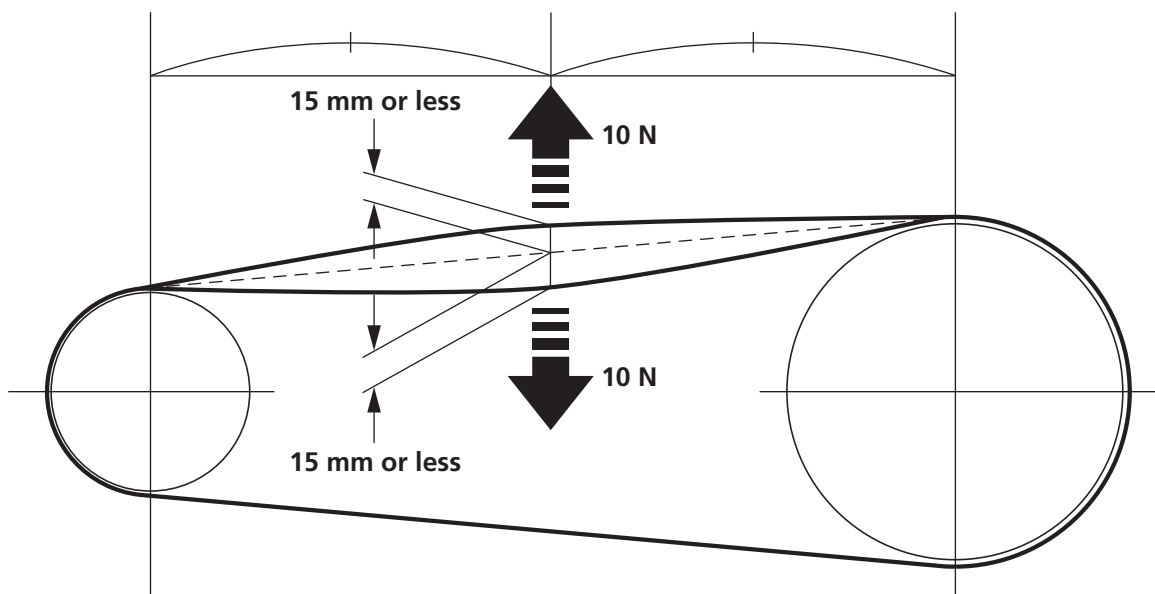

HANDLING THE BATTERY

Installing the Battery

The battery is secured to the battery mount with a key. There are several types of keys, so there may be differences with the explanation below.

⚠ CAUTION

- Firmly hold the battery during installation, being careful not to drop it.
- Keep the following in mind to prevent the battery from dropping while riding.
 - Check that the battery is locked firmly with the battery mount.
 - Do not ride with the key inserted.

NOTICE

- Check that the charging port cap is closed before riding.

TECH TIPS

- The battery can be inserted without turning the key.

Rear carrier mount type

1. Insert the battery into the rail from the rear of the bicycle.

Slide the battery to the front and push it in firmly.

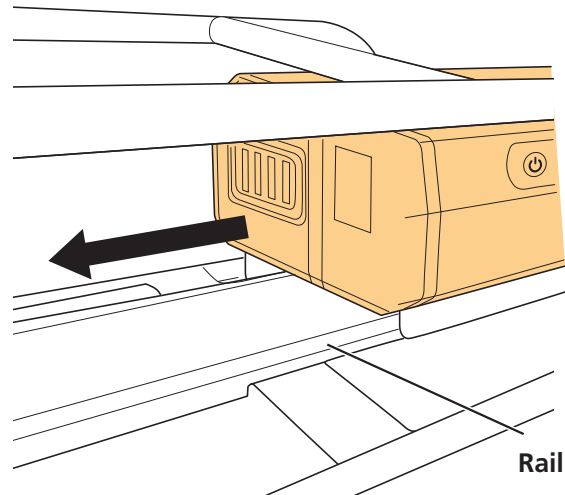

2. Remove the key.

Return the key to the locked position, and then remove it.

Down tube mount type

1. Insert the battery from below.

Align the concave section on the bottom of the battery with the convex section on the battery mount, and then insert the battery.

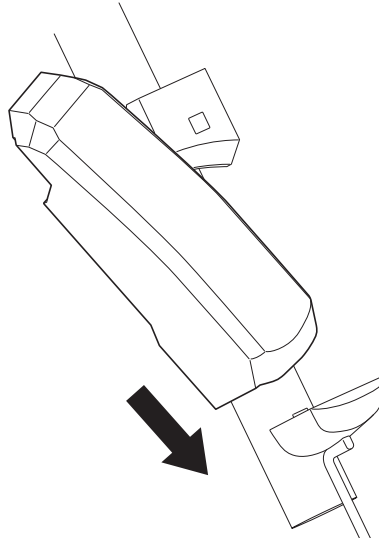

2. Slide the battery.

Push it in firmly until you hear it click into place.

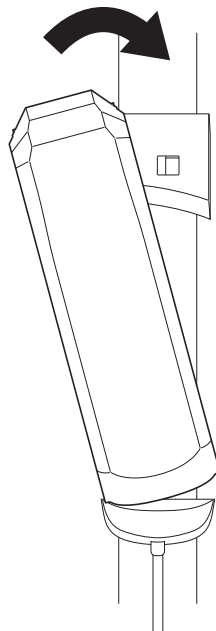

3. Remove the key.

Return the key to the locked position, and then remove it.

Built-in type

The following procedure uses a type of frame where the battery is installed/removed from its lower side as an example.

1. Use the following procedure to insert from the lower side of the battery.

- (1) Insert from the lower side of the battery.
- (2) Slide the battery. Push it in firmly until you hear it click into place.

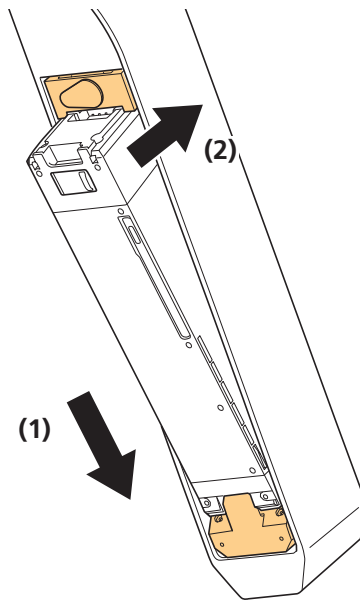

Removing the Battery

⚠ CAUTION

- Firmly hold the battery during removal or transport, being careful not to drop it.

Rear carrier mount type

1. Insert the key and release the lock.

- (1) Turn the power OFF, and then insert the key into the socket on the battery mount.
- (2) Turn the key until you feel it make contact.

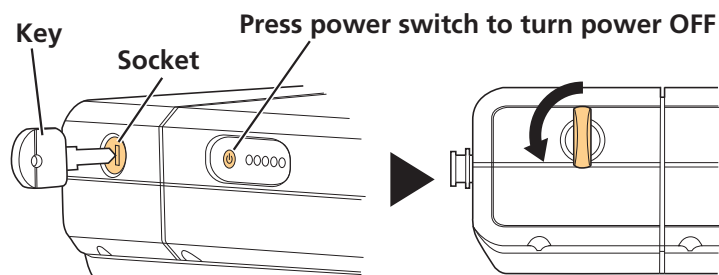

2. Carefully remove the battery.

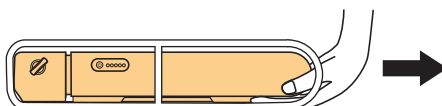

Down tube mount type

1. Insert the key.

Turn the power OFF, and then insert the key into the socket on the battery mount.

<BT-E6010>

Press power switch to turn power OFF

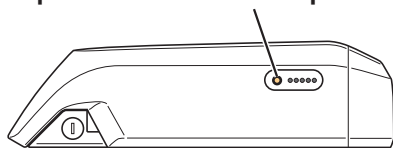

<BT-E8010/BT-E8014>

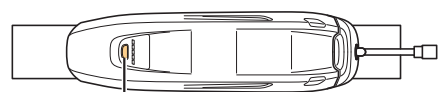

Press power switch to turn power OFF

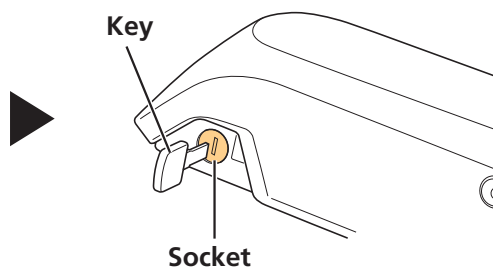

2. Release the battery lock.

Turn the key until you feel it make contact.

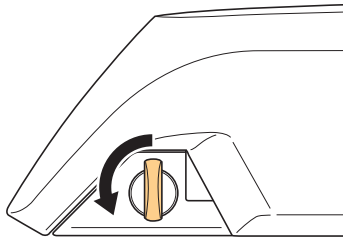

3. Slide and carefully remove the battery.

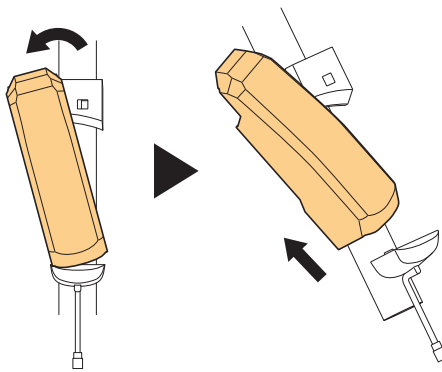

Built-in type

If a battery cover from another company is installed, remove the battery cover first. The following procedure uses a type of frame where the battery is installed/removed from its lower side as an example.

1. Open the socket cap.

Turn the power OFF, and then open the socket cap.

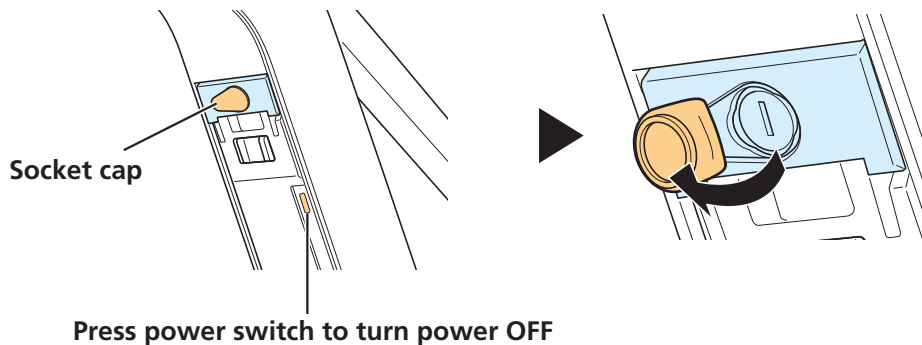

2. Release the battery lock.

(1) Insert the key into the socket on the battery mount.

(2) Turn the key.

* The plate spring will hold the battery and prevent it from dropping.

(3) Push the key in to release the lock.

* The battery lock will be released, so be sure to hold it firmly.

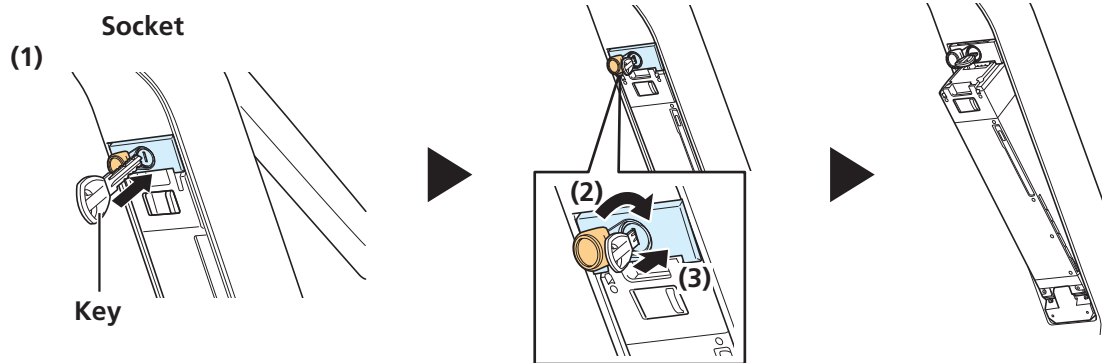

3. Remove the battery.

(1) Remove the key, and then close the socket cap.

(2) Carefully remove the battery.

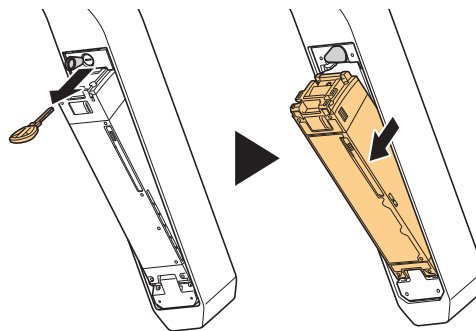

NOTICE

- Do not install or remove the battery with the key inserted or the socket cap left open. The battery could make contact with the handle on the key or the socket cap, damaging it.

Charging the Battery

Deep sleep mode

The battery will be in deep sleep mode immediately after shipment, so it cannot be used right away. Charging the battery using the designated battery charger will cancel deep sleep mode, allowing the battery to be used. The battery can be used when the LED on it turns on.

TECH TIPS

- You can also cancel deep sleep mode by connecting a completed bicycle (i.e. a bicycle to which all components have been assembled) to E-TUBE PROJECT.

NOTICE

Although the battery can be charged regardless of the battery level, fully charge the battery in the following situation. Use the designated battery charger to charge the battery.

- The battery is not fully charged at the time of shipment. Before riding, be sure to fully charge the battery.

If the battery has become completely empty, charge it as soon as possible. Leaving the battery discharged could cause it to deteriorate.

- If the bicycle will not be ridden for a long period, store with the battery level around 70%. Charge the battery every six months to prevent the battery from fully discharging.
- Do not connect to E-TUBE PROJECT while the battery is being charged.

It is recommended to use a genuine SHIMANO battery. If using a battery from another company, be sure to read the product manual thoroughly prior to use.

- You can check whether a battery is a SHIMANO genuine battery or a battery from another company by connecting to E-TUBE PROJECT and running the [Connection check] menu.

⚠ DANGER

- Use the specified battery and battery charger combination for charging and observe the specified charging conditions. Doing otherwise may cause overheating, bursting, or ignition.

⚠ CAUTION

- When charging a battery attached to the bicycle, be careful not to pull the charging cable. Doing so could cause injury, or could cause the bicycle to tip over, damaging components.

NOTICE

- When removing the battery charger's power plug from the electrical outlet or removing the power plug from the battery, do not pull while holding the cord. Doing so may cause damage.
- If the bicycle is stored for an extended period of time immediately after purchase, you will need to charge the battery before using the bicycle. Once the battery is charged, the charging capacity starts to deteriorate slightly.

Charging time

The charging time will vary depending on the maximum capacity of the battery, the battery level, and the battery charger being used.

▶ Designated charging time

The charging time from a battery level of 0% is as shown below.

| Battery | Designated charging time | |
|--------------------------------|---------------------------|---------------------------|
| | Battery charger: EC-E6002 | Battery charger: EC-E6000 |
| BT-E6000 / BT-E6010 / BT-E8014 | About 6.5 hours | About 4 hours |
| BT-E6001 / BT-E8010 / BT-E8020 | About 7.5 hours | About 5 hours |

⚠ WARNING

- If the battery does not become fully charged even 2 hours after the designated charging time, immediately unplug the battery from the electrical outlet and contact the place of purchase. Doing otherwise may cause overheating, bursting, or ignition.

Charging the battery removed from the bicycle

Charge the battery placed on a level surface indoors.

▶ BT-E6000/BT-E6001/BT-E6010

An adapter (SM-BTE60: sold separately) is required to charge BT-E6000/BT-E6001/BT-E6010 removed from the bicycle.

1. Open the socket cap.

- (1) Install the adapter to the charging plug.
- (2) Connect the battery charger's power plug to the electrical outlet.
- (3) Install the adapter to the battery's charging port.

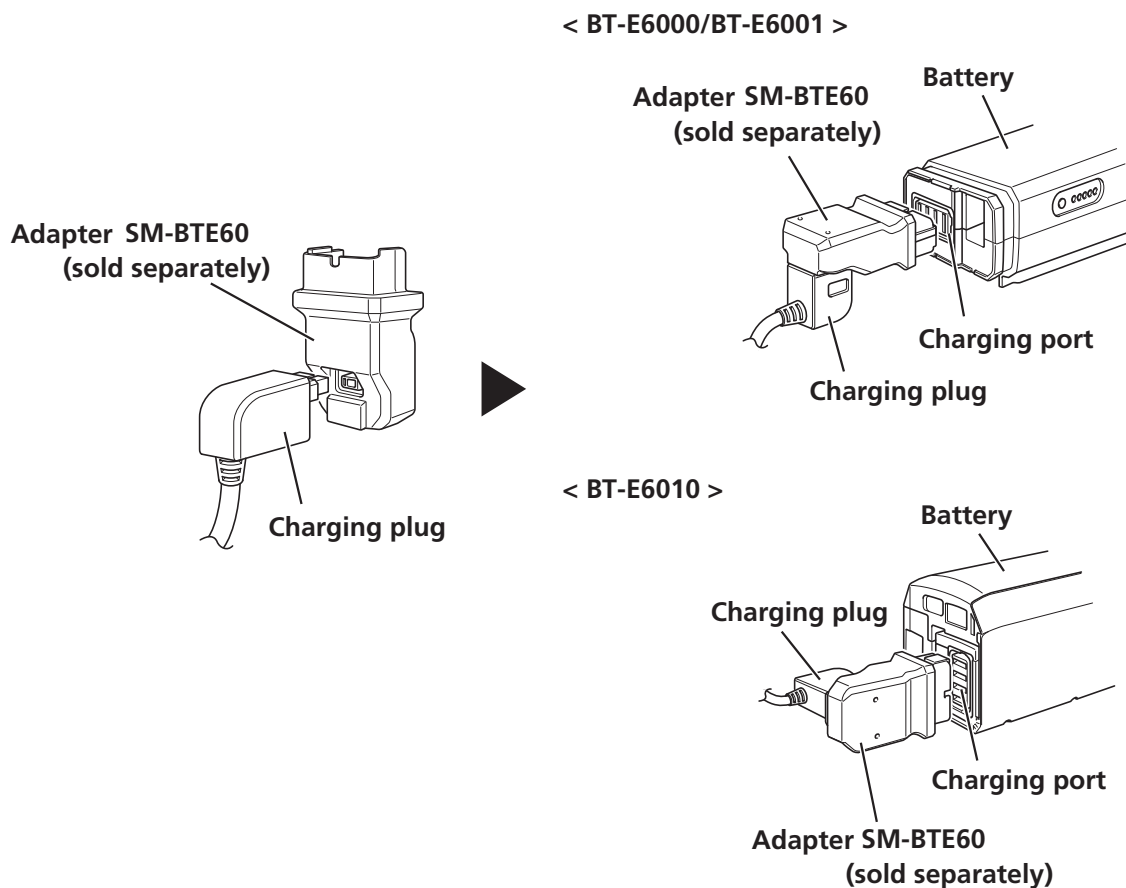

▶ BT-E8010/BT-E8014/BT-E8020

1. Connect the battery charger's power plug to the electrical outlet.
2. Install the charging plug to the battery's charging port.

< BT-E8010/BT-E8014 >

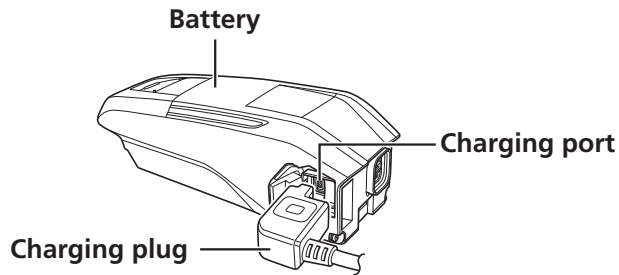

< BT-E8020 >

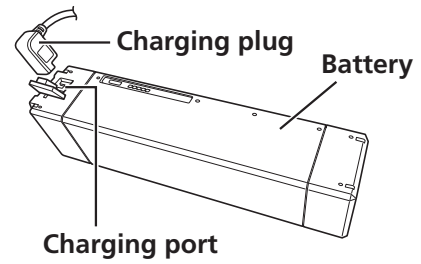

Charging the battery attached to the bicycle

Charge the battery with the battery charger placed on the floor or some other stable surface. Fix the bicycle in place when charging, so that it does not tip over.

1. Connect the battery charger's power plug to the electrical outlet.
2. Insert the charging plug into the charging port on the battery mount or battery.

<BT-E6000/BT-E6001>

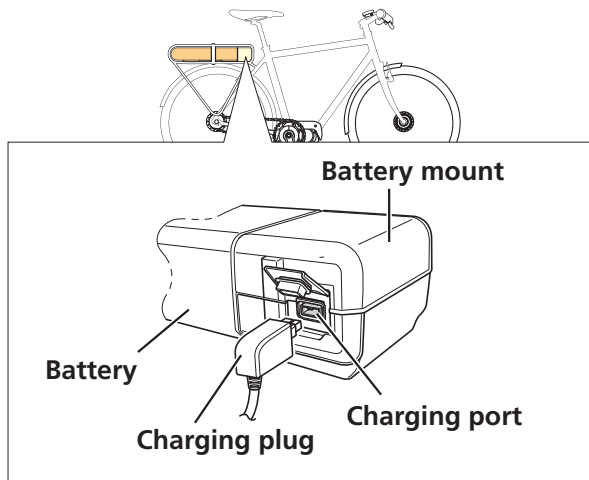

<BT-E8020>

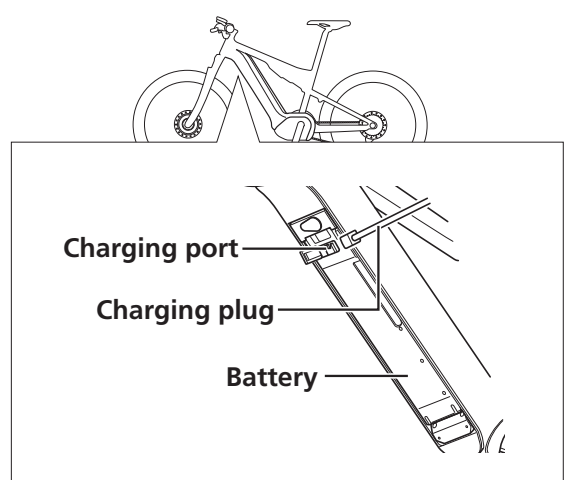

<BT-E6010/BT-E8010/BT-E8014>

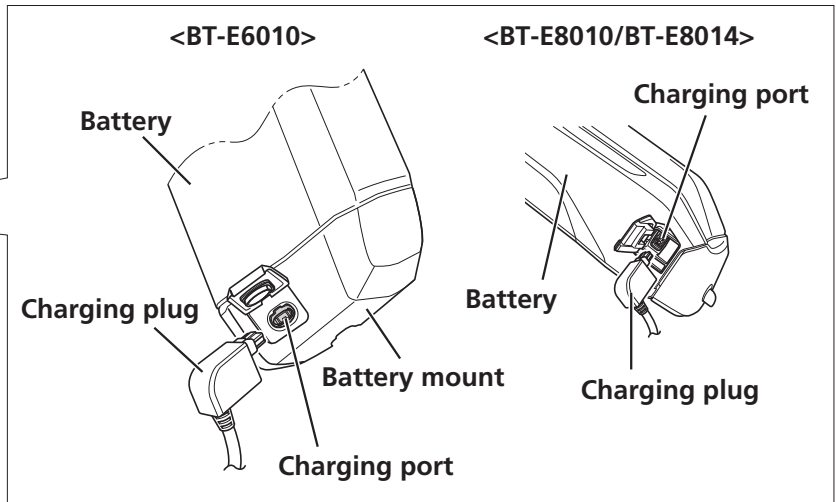
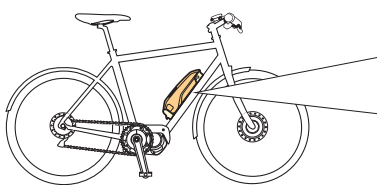

3. After charging, firmly close the charging port cap.

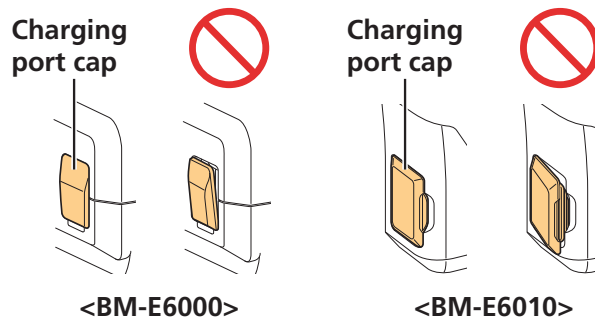

Battery charger LED indication

Once charging has started, the LED on the battery charger lights up.

| | | |
|------------|-------------------|--|
| ● Lit up | Charging | <div style="display: flex; justify-content: space-around;"> <div style="text-align: center;"> <p><EC-E6000></p> <p>Battery charger LED</p> </div> <div style="text-align: center;"> <p><EC-E6002></p> <p>Battery charger LED</p> </div> </div> |
| ● Flashing | Charge error | |
| ● Off | Charging complete | |





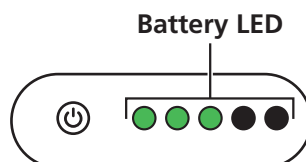

Battery LED indication

The LED on the battery can be used to check the charging status of the battery and the battery level. The shape of the LED differs depending on the model number.



▶ Display while charging







When charging, the battery LED lamp will light up as follows.

| LED indication*1 | Charging status |
|---|-----------------|
|  | 0% - 20% |
|  | 21% - 40% |
|  | 41% - 60% |
|  | 61% - 80% |
|  | 81% - 99% |
|  | 100% |

*1 ● Off ● Lit ☀ Flashing

▶ Battery level display

When the battery power button is used to turn the power from OFF to ON, the LED indication can be used to check the current battery level.

| LED indication*1 | Charging status |
|---|--|
|  | 100% - 81% |
|  | 80% - 61% |
|  | 60% - 41% |
|  | 40% - 21% |
|  | 20% - 1% |
|  | 0% * If the battery is not attached to the bicycle |
|  | 0% * If the battery is attached to the bicycle * If the power is OFF |

*1 ● Off ● Lit ● Flashing

TECH TIPS

• When the battery level is low, system functions will be shut off in the following order.

(1) Power assist

* The assist mode will automatically switch to [ECO], and then assist will be shut off. If using a light connected to the drive unit, the mode will switch more quickly to [ECO].

(2) Electronic gear shifting

(3) Lights

OPERATION AND SETTING

Turning Power ON/OFF

The main power can be turned ON/OFF using the cycle computer or the battery power button.

NOTICE

- Check the following prior to turning the power ON.
 - The battery is firmly attached to the battery mount
 - The cycle computer is firmly attached to the bracket
- Do not place your foot on the pedal when operating the power. Doing so could cause a system error.

TECH TIPS

- When the main power is turned ON, all components connected to the drive unit are also turned ON (such as assist driving, cycle computer power, the electronic gear shifting mechanism, and the lights).
- The power cannot be turned ON while charging.
- If the bicycle is left unused for 10 minutes after turning the power ON, the power automatically turns OFF. (This is the automatic power OFF function.)

Operating power from the cycle computer

- The cycle computer also contains a built-in battery. Power cannot be operated unless this built-in battery is sufficiently charged. In this case, use the battery power button instead.
- The cycle computer's built-in battery is charged from the main battery. It is only charged when it is attached to the bicycle, the main power is turned ON, and the display is lit up.

1. Press the power switch for around two seconds.

The main power turns ON.

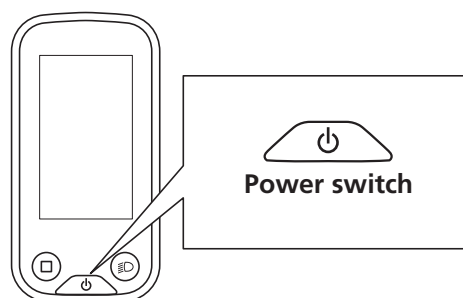

Operating power from the battery

1. Press the battery power button.

The LED lamp lights up and the battery level is displayed.

<BT-E6000/BT-E6001>

Power switch

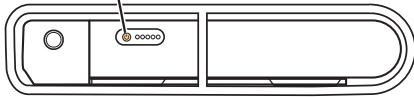

<BT-E8010/BT-E8014>

Power switch

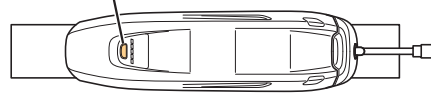

<BT-E6010>

Power switch

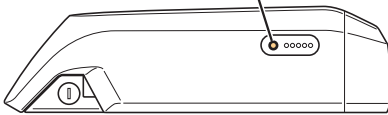

<BT-E8020>

Power switch

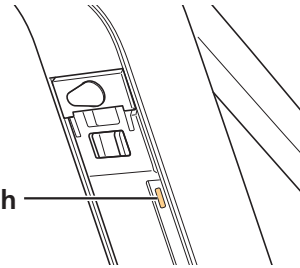



TECH TIPS

- Pressing the battery power button on a BT-E8010/BT-E8020 battery for around six seconds will force the power OFF for emergencies.

Screen display when power is ON

▶ SC-E6100

When the main power is turned ON, a screen similar to that shown below is displayed, and then switches to the basic screen.

| Normal startup | Battery level low |
|---|---|
|  |  |
| | <p>* The cycle computer's battery level is low.</p> |

▶ EW-EN100

When the main power is turned ON the LED (outward) lights up.

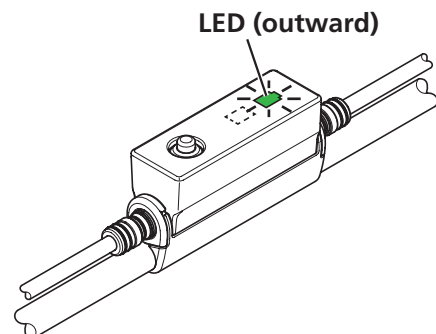

Basic Operation

This manual uses default settings for all explanations. The functions assigned to switches when riding can be changed from those described here, by connecting to E-TUBE PROJECT.

Cycle computer and switch unit

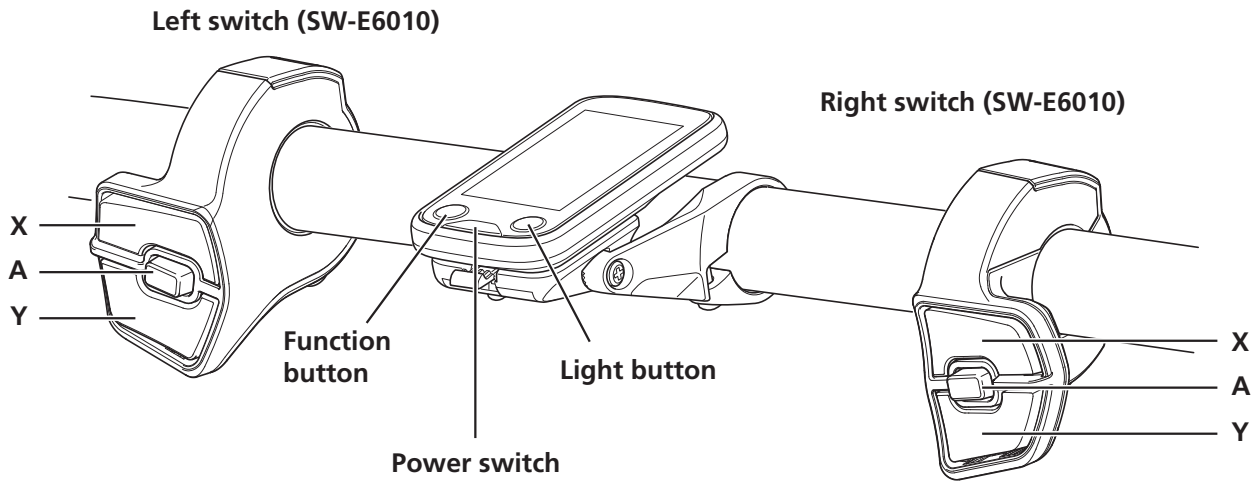

Left switch (SW-M8050)

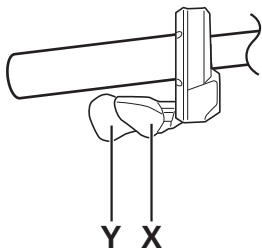

Right switch (SW-M8050)

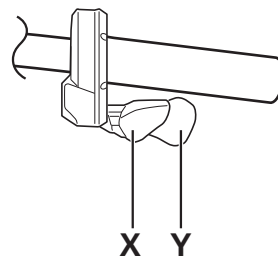

| Left switch (default: assist) | | Right switch (default: electronic gear shifting) | |
|--|---|---|--|
| Assist-X | When riding: Increase assistance When setting: Move cursor or change setting | Shift-X | When riding: Shifting up |
| Assist-Y | When riding: Decrease assistance When setting: Move cursor or change setting | Shift-Y | When riding: Shifting down |
| Assist-A | When riding: Switch traveling data displayed on cycle computer When setting: Switch cycle computer screen or confirm setting changes | Shift-A | Switch between automatic and manual gear shifting (for electronic gear shifting/internal geared hub models) |

| Cycle computer (SC-E6100) | | | |
|----------------------------------|---|---------------------|-------------------|
| Function button | When riding: Switch traveling data displayed on cycle computer When setting: Switch cycle computer screen or confirm setting changes | Light button | Light ON/OFF |
| | | Power switch | Main power ON/OFF |

NOTICE

- When using a rear derailleur, be sure to keep turning the crank during gear shifting operations.

Junction (A) (EW-EN100)

EW-EN100, which can be used instead of a cycle computer, offers functionality to change assist modes.

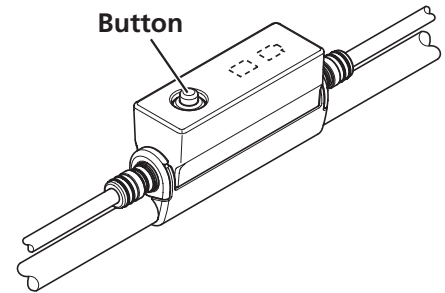

Junction (A)

Button

Press: Change assist mode (each time button is pressed)
Hold (around two seconds): Light ON/OFF

NOTICE

- It is not recommended to operate the button on EW-EN100 while riding. Select your preferred assist mode prior to riding.

TECH TIPS

- A switch unit connection is required to change to walk assist mode.
- Functionality to switch to the setting mode is also assigned to a button. Refer to "Setting Mode (EW-EN100)" in "OPERATION AND SETTING."

Light ON/OFF

If a light is connected to the drive unit, the cycle computer or junction (A) can be used to operate the light.

TECH TIPS

- The light turns OFF when the main power is turned OFF. The light will not turn ON when the main power is OFF.

SC-E6100

1. Press the light button.

- The light turns on. The light icon is also displayed on the screen.
- Press the light button again to turn the light OFF.

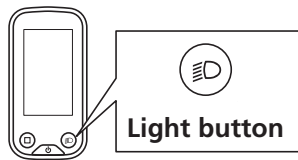

When the light is turned on



When the light is turned off



TECH TIPS

- If no light is connected to the drive unit, setting [Backlight] in the cycle computer setting menu to [MANUAL] will allow you to turn the backlight ON/OFF (only) using the light button on the cycle computer. However, even if the backlight is turned ON the icon showing that the light is ON will not be displayed on the screen.

EW-EN100

The light cannot be turned OFF by pressing the button while riding.

1. Hold the button down until the light turns ON (around two seconds).

When the light turns ON, the LED (inward) will flash.

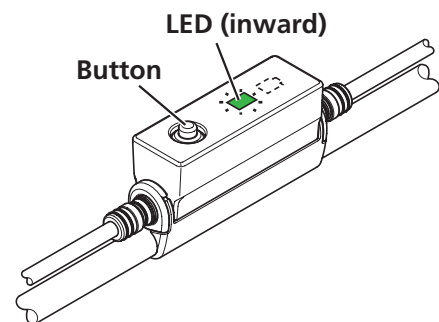

Basic Status Display



SC-E6100

This displays the status of the bicycle and traveling data. The gear position is only displayed for electronic gear shifting.

The display may vary depending on the connected electronic gear shifter.

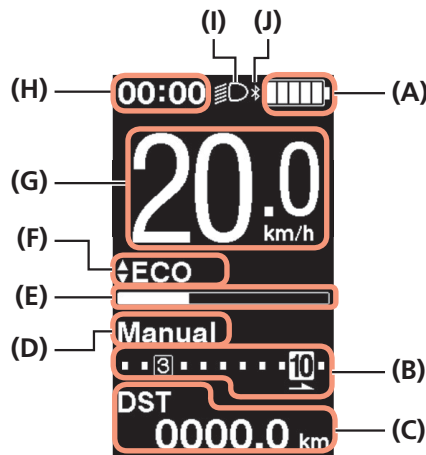
<SC-E6100 basic screen>



| | | | | |
|-----|---|--|-----|--|
| (A) | Battery level indicator | | (E) | Assist gauge Displays the assist level. |
| (B) | Gear position display | | (F) | Current assist mode |
| |  | Current gearposition | | |
| |  | Start mode gear position*1 | (G) | Current speed |
| |  | Gear shifting advice*2 Displayed when providing gear shifting advice based on the status of the bicycle. | (H) | Current time |
| (C) | Traveling data display | | (I) | Light icon Displayed when the light connected to the drive unit is ON. |
| (D) | Gear shifting mode*3 Displays the current gear shifting mode ([Auto] or [Manual]). | | (J) | Bluetooth® LE icon Only displayed when an external device is connected over Bluetooth® LE. |

*1 Electronic gear shifting/internal geared hub models only.

*2 Only for electronic gear shifting with the gear shifting mode set to [Manual].

*3 [Manual] will always be displayed for rear derailleur models.

EW-EN100

The LEDs indicate the following statuses.

- Current battery level
- Current assist mode

Refer to "Battery level indicator" (next section) in "OPERATION AND SETTING" and "Switching the Assist Mode" in "OPERATION AND SETTING."

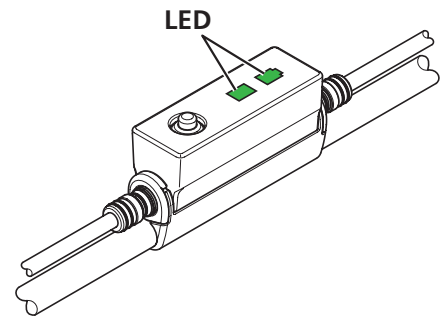







Battery level indicator

This allows you to check the battery level while riding.





▶ SC-E6100

The battery level is shown as an icon.

| Display | Battery level |
|---|---------------|
|  | 81 - 100% |
|  | 61 - 80% |
|  | 41 - 60% |
|  | 21 - 40% |
|  | 1 - 20% |
|  | 0% |

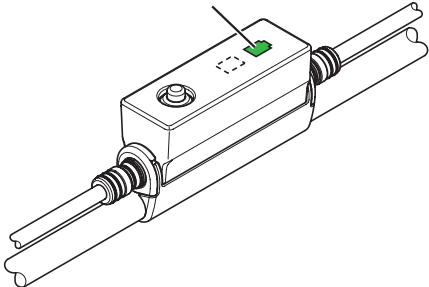
▶ EW-EN100

The LED (outward) shows the battery level when the power is ON.

| LED (outward) display | Battery level |  |
|--|---------------|--|
|  (lit up) | 100 - 21% | |
|  (lit up) | 20% or less | |
|  (flashing) | Nearly empty | |

Switching the Assist Mode

Switching the assist mode with the switch unit

1. Press Assist-X or Assist-Y.

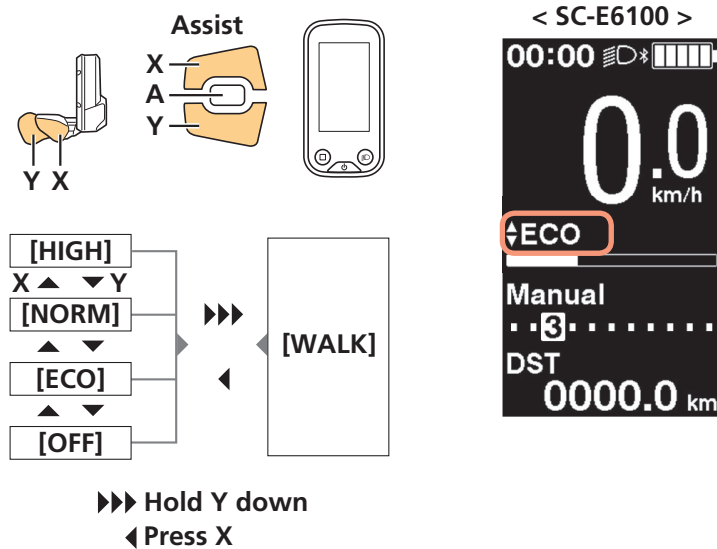

TECH TIPS

- If a switch unit is connected to EW-EN100, the LED will indicate the assist mode (as shown in the next section).

Switching the assist mode with EW-EN100

Explain to the customer that it is not recommended to operate the device while riding.

1. Press the button.

The assist mode switches each time the button is pressed. The LED (inward) display switches each time the assist mode is switched.

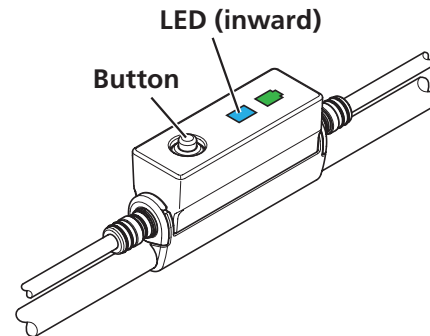
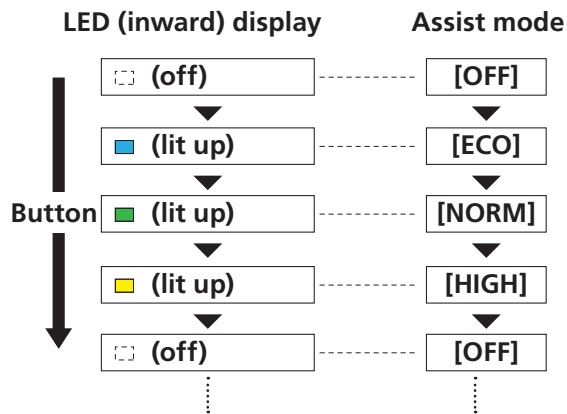

Walk Assist Mode

- The use of the walk assist mode function is prohibited by law in some regions.
- The walk assist function operates at a maximum of 6 km/h. During electronic gear shifting, the assist level and speed are controlled by the gear position.
- Switching to walk assist mode requires a switch unit that has been assigned the change assist mode function.

Switching to walk assist mode

1. Stop the bicycle.

Release your feet from the pedals.

2. Hold down Assist-Y until it reaches the following state (around two seconds).

- SC-E6100: The assist mode shown on the display switches to [WALK].
- EW-EN100: The LED (inward) lights up blue.

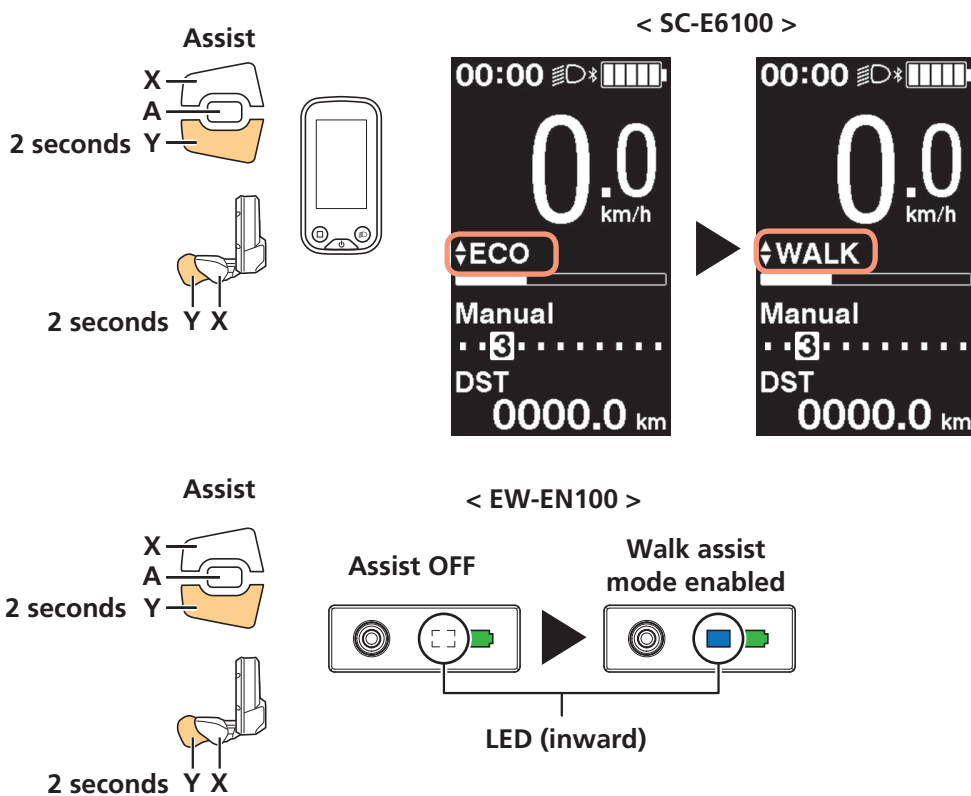

NOTICE

- If it is impossible to switch to walk assist mode for any reason (the bicycle is not stopped, there is pressure applied to the pedals, etc.), a warning sound will be played.

TECH TIPS

- If nothing is done for one minute after switching to walk assist mode, it will switch back to the assist mode that was selected before switching.

Walk assist mode operation

Prior to operation, firmly grip the handlebar and note your surroundings. When walk assist begins, the bicycle will be driven by the drive unit.

1. Continue to press Assist-Y while in walk assist mode.

- Walk assist will function only while Assist-Y is pressed.
- If a switch unit is connected to EW-EN100, the LED (inner side) will flash blue when walk assist starts.

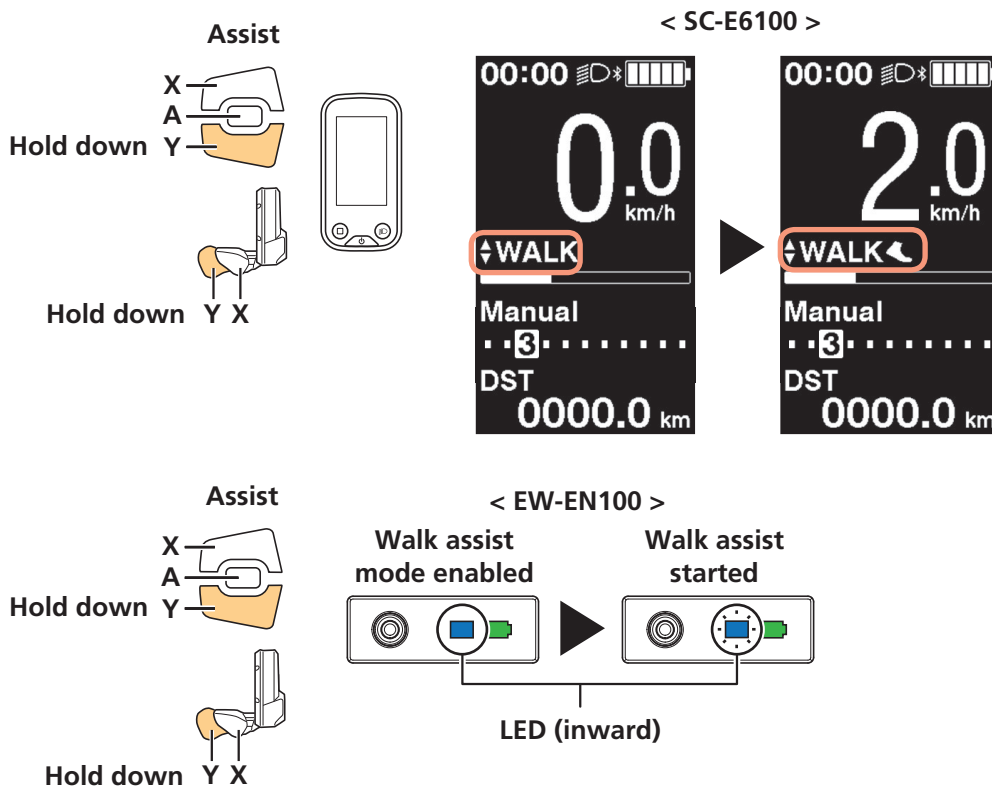

2. Carefully push the bicycle together with walk assist.

3. Removing your finger from Assist-Y will stop walk assist.

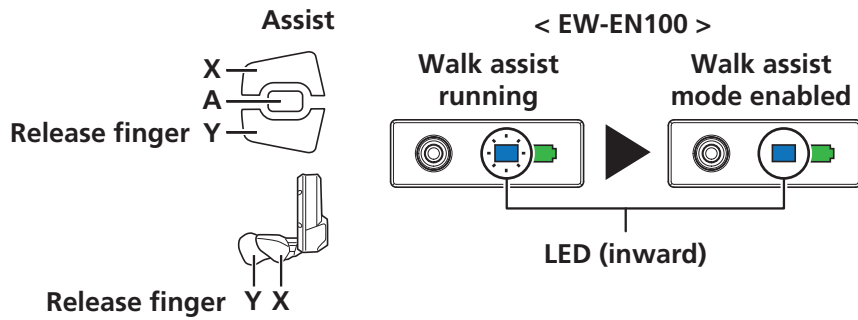
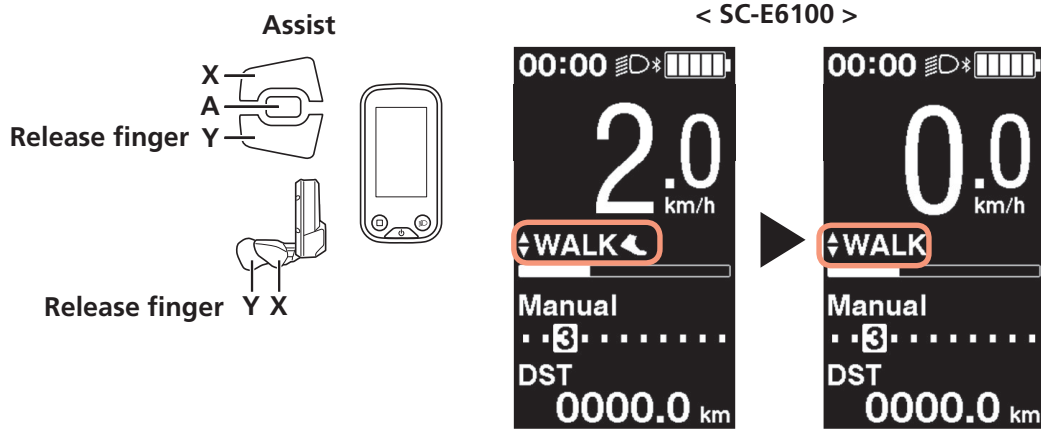

4. Press Assist-X to exit walk assist mode.

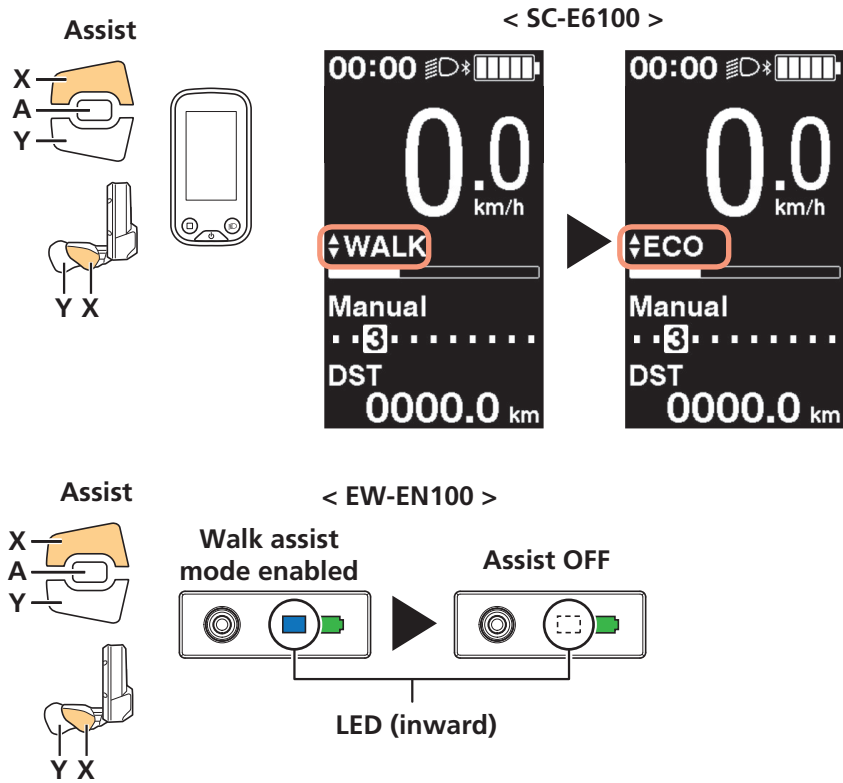

Switching Traveling Data Display (SC-E6100)

1. Switch the traveling data display.

The traveling data display will switch each time any of the following is performed.

- Press Assist-A.
- Press the cycle computer's function button.

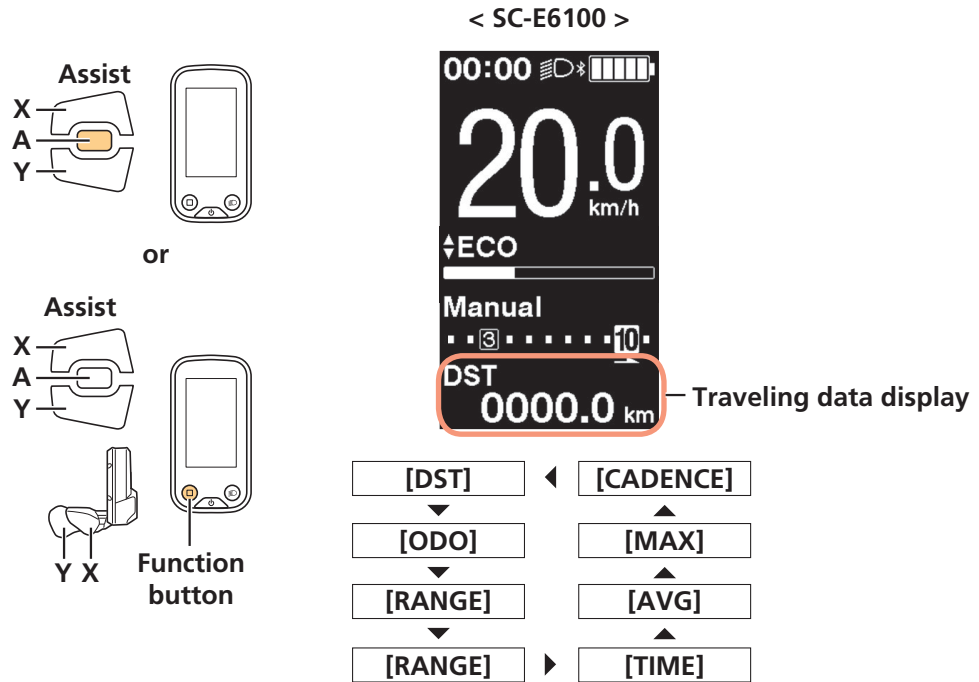

| Display item | Explanation |
|--------------|---|
| [DST] | Traveling distance*1 |
| [ODO] | Cumulative distance |
| [RANGE] | Maximum traveling distance*2 |
| [RANGE] | Maximum traveling distance for each assist mode*2*3*4 |
| [TIME] | Traveling time*4 |
| [AVG] | Average speed*4 |
| [MAX] | Maximum speed*4 |
| [CADENCE] | Crank rotation speed*4 |

*1 Traveling data can be reset by holding Assist-A while displaying [DST]. The [ODO] information will not be reset.

*2 The maximum traveling distance should be used as a reference only.

*3 Will be displayed as shown in the figure below. The gear position cannot be displayed while this is being shown.

| | |
|--------------|--------------|
| RANGE | |
| HIGH | 61 km |
| NORM | 77 km |
| ECO | 97 km |

*4 This item is optional. Whether to show this or not can be set by connecting E-TUBE PROJECT. Refer to "Items Configurable in E-TUBE PROJECT" in "CONNECTION AND COMMUNICATION WITH DEVICES."

Resetting the traveling distance

Reset the traveling distance displayed on the basic screen. When the traveling distance is reset, [TIME] (traveling time), [AVG] (average speed), and [MAX] (maximum speed) will also be reset.

1. Press Assist-A or the function button to switch the traveling data display to [DST].

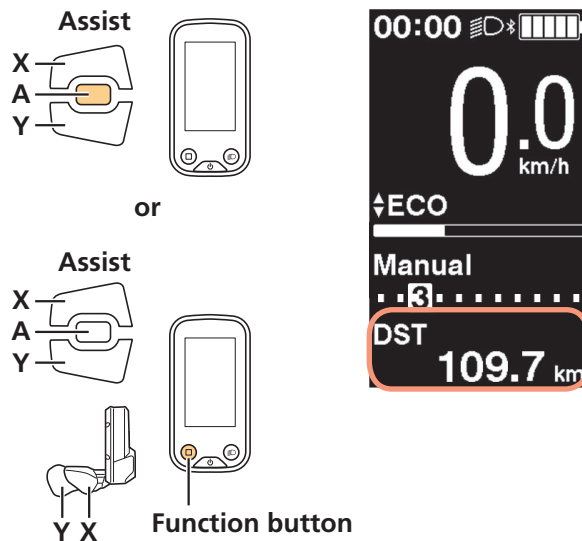

2. Continue to hold Assist-A until the number displayed for [DST] flashes.

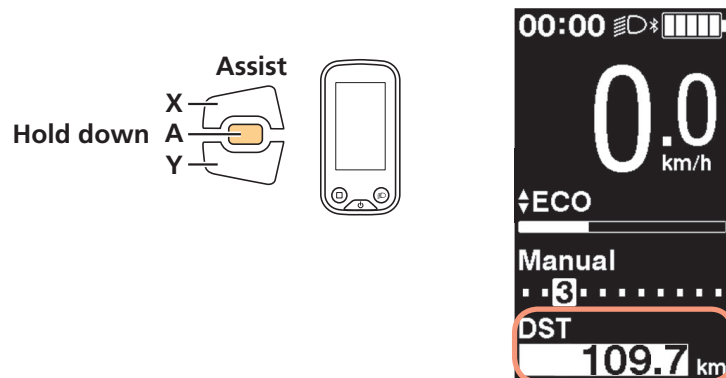

3. Press Assist-A again.

- The traveling data is cleared.

TECH TIPS

- If nothing is done for five seconds after the number for [DST] begins flashing, it will stop flashing and the screen will return to the basic screen.

Switching the Gear Shifting Mode (SC-E6100)

It is possible to switch between automatic and manual gear shifting for electronic gear shifting internal geared hub models.

NOTICE

- This works for 5-speed and 8-speed electronic gear shifting internal geared hubs.

1. Press Shift-A while the basic screen is displayed.

The setting switches between [Manual] and [Auto] each time Shift-A is pressed.

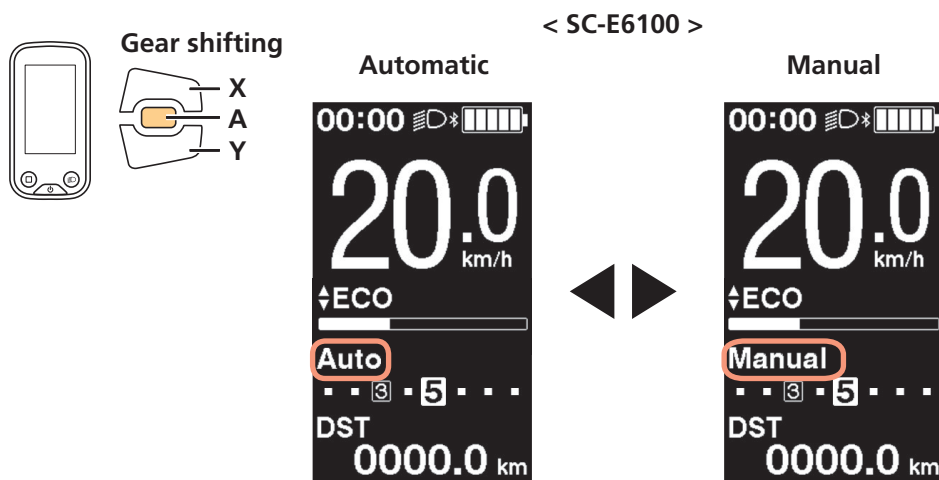

| Selectable items | Explanation |
|------------------|---|
| [Auto] | Automatically shifts gears based on the load on the pedals. |
| [Manual] | Gears are shifted by operating the shifting switch. |

NOTICE

- [Manual] will be shown on the display and cannot be changed for electronic gear shifting rear derailleur models or mechanical gear shifting.

Setting Menu (SC-E6100)

Startup

Displays the SC-E6100 setting menu.

1. Stop the bicycle.

2. Perform the following to switch to the setting menu.

- Hold down the function button until the screen switches to the setting menu.
- Hold down Assist-X and Assist-Y together until the screen switches to the setting menu.

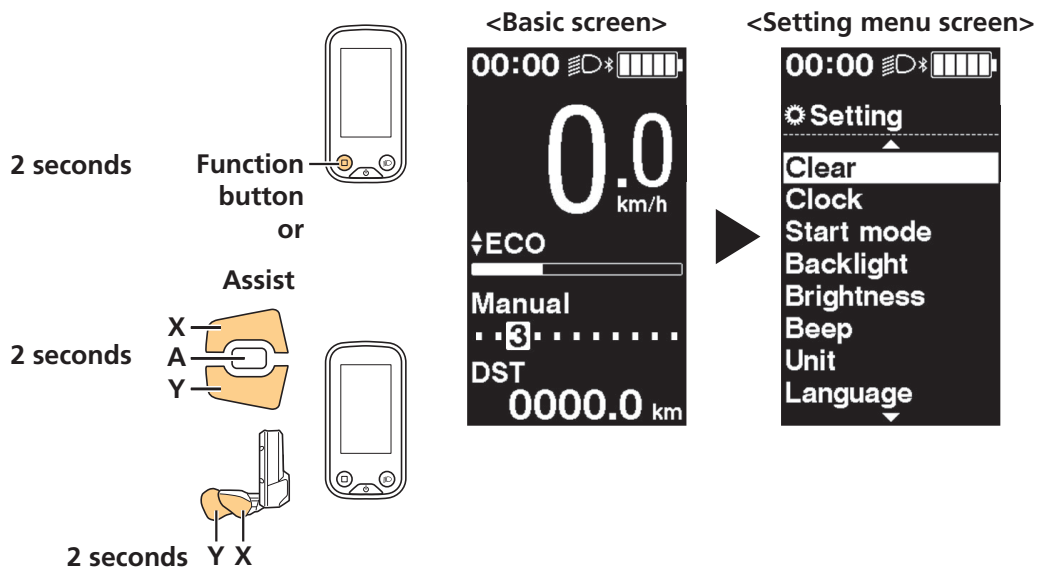

3. Select a menu item.

(1) Press Assist-X or Assist-Y to move the cursor.

(2) Press Assist-A or the function button.

* The display switches to the screen for the selected item.

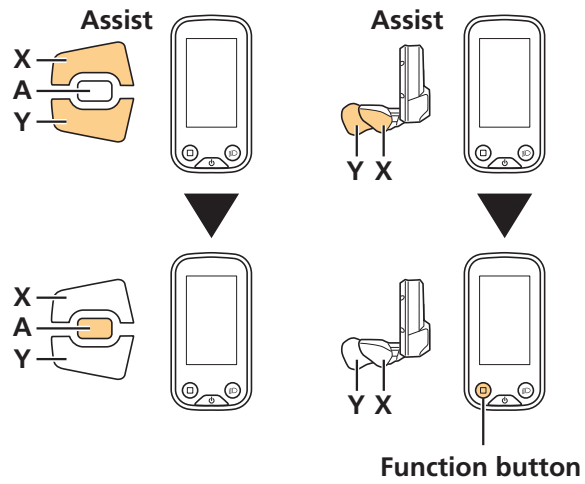

| Selectable items | Explanation |
|--------------------------|---|
| [Clear] | Resets the traveling distance and display settings. |
| [Clock] | Sets the current time. |
| [Start mode] *1 | Automatically shifts to the set gear position when the bicycle starts from a stop. |
| [Backlight] | Sets the display backlight. |
| [Brightness] | Sets the display brightness. |
| [Beep] | Turns the operation sound ON/OFF. |
| [Unit] | Switches the display unit between km and mile. |
| [Language] | Sets the display language. |
| [Font color] | Switches the font color between black and white. |
| [Adjust] *2 | Adjusts gear shifting for the electronic gear shifter. |
| [Shift timing] *2 | Adjusts the gear shifting timing during automatic gear shifting. Also sets the timing at which gear shifting advice is displayed. |
| [Shifting advice] *2 | Sets whether to display the recommended gear shifting timing on the cycle computer during manual gear shifting. |
| [RD protection reset] *3 | Performs RD Protection Reset. |
| [Exit] | Returns to the basic screen. |

*1 Electronic gear shifting/internal geared hub models only.

*2 Electronic gear shifting only.

*3 Electronic gear shifting rear derailleur models only.

[Clear]

Resets the traveling distance and display settings.

- When the traveling distance is reset, [TIME] (traveling time), [AVG] (average speed), and [MAX] (maximum speed) will also be reset.
- When the display settings are reset, they will return to the default settings as shown below.

| | | | | | |
|-------------|------|--------------|-----------|--------------|---------|
| [Backlight] | [ON] | [Brightness] | [3] | [Beep] | [ON] |
| [Unit] | [km] | [Language] | [English] | [Font color] | [White] |

1. Display the [Clear] menu.

- (1) Display the setting menu.
- (2) Press Assist-X or Assist-Y, select [Clear], and then press Assist-A or the function button.

2. Press Assist-X or Assist-Y to select the item to reset.

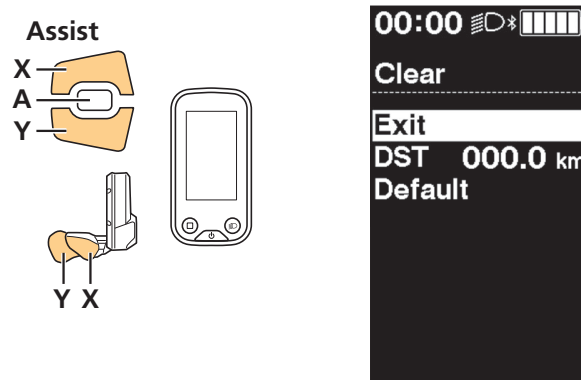

| Selectable items | Explanation |
|------------------|--------------------------------|
| [Exit] | Returns to the setting menu. |
| [DST] | Resets the traveling distance. |
| [Default] | Resets the display settings. |

3. Press Assist-A or the function button to reset the selected item.

The display will automatically return to the setting menu.

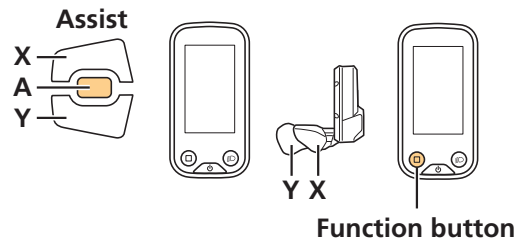

[Clock]

Sets the current time. First set the "Hour" and then the "Minute." When setting numbers in steps 2 and 4, you can hold Assist-X or Assist-Y to quickly change numbers.

1. Display the [Clock] menu.

- (1) Display the setting menu.
- (2) Press Assist-X or Assist-Y, select [Clock], and then press Assist-A or the function button.

2. Press Assist-X or Assist-Y to change the "Hour" number.

- Press Assist-X to increase the number.
- Press Assist-Y to decrease the number.

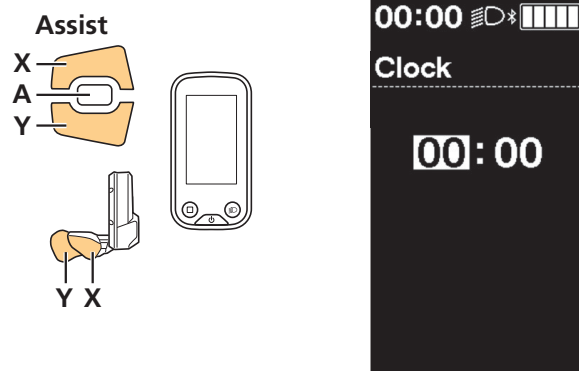

3. Press Assist-A or the function button to finalize the setting.

The cursor moves to the "Minute" number.

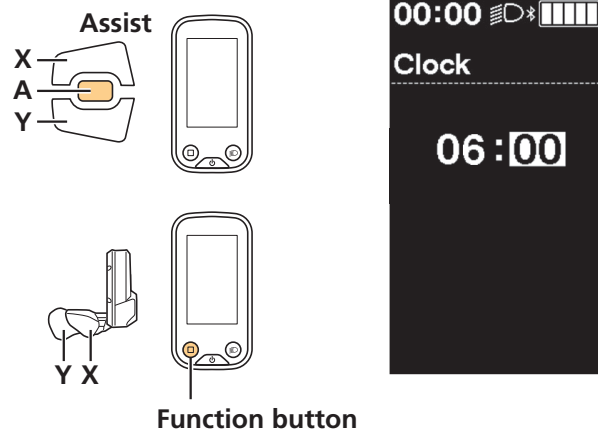

4. Press Assist-X or Assist-Y to change the "Minute" number.

- Press Assist-X to increase the number.
- Press Assist-Y to decrease the number.

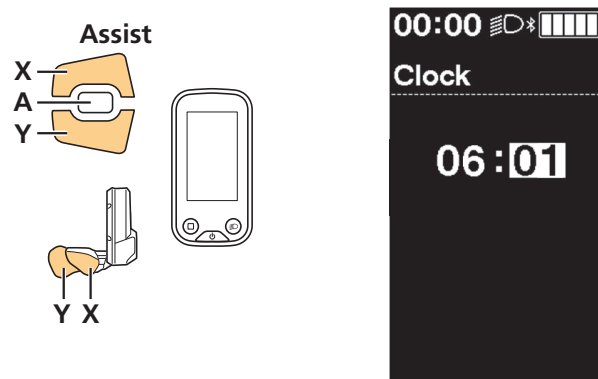

5. Press Assist-A or the function button to finalize the setting.

The display will automatically return to the setting menu.

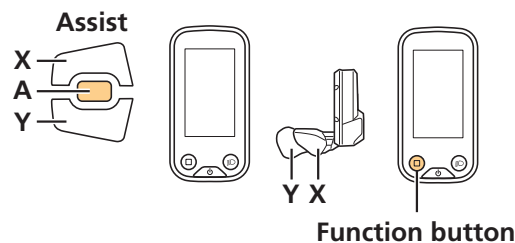

[Start mode]

Automatically shifts to the set gear position when the bicycle starts from a stop.

1. Display the [Start mode] menu.

(1) Display the setting menu.

(2) Press Assist-X or Assist-Y, select [Start mode], and then press Assist-A or the function button.

2. Press Assist-X or Assist-Y to select the item to set.

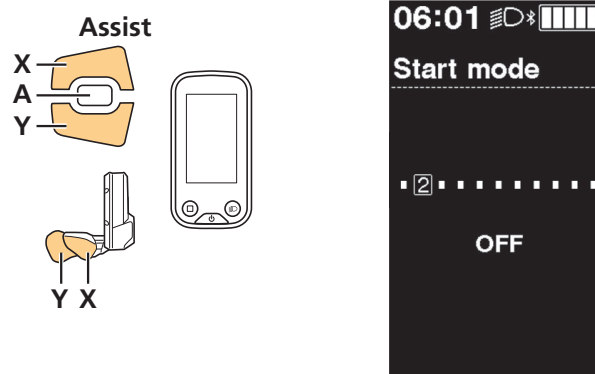

| Selectable items | Explanation |
|------------------|--|
| [OFF] | Do not set the start mode. |
| [1 - 11] | Select the gear position from 1 to 11. |

3. Press Assist-A or the function button to finalize the selected setting.

The display will automatically return to the setting menu.

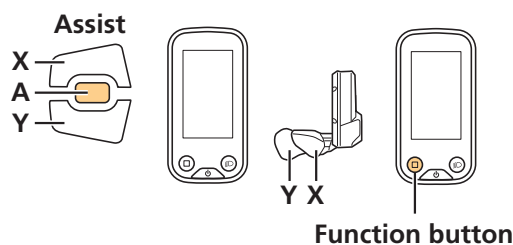

[Backlight]

Sets the display backlight.

1. Display the [Backlight] menu.

- (1) Display the setting menu.
- (2) Press Assist-X or Assist-Y, select [Backlight], and then press Assist-A or the function button.

2. Press Assist-X or Assist-Y to select the item to set.

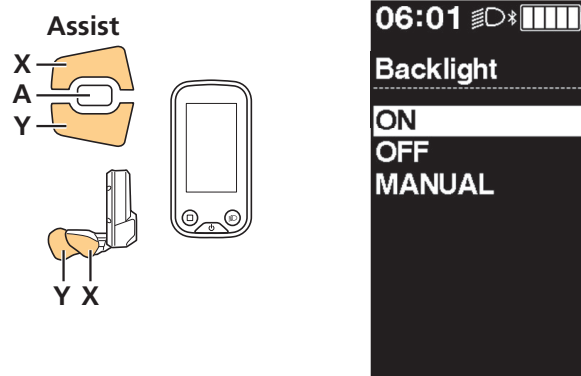

| Selectable items | Explanation |
|------------------|--|
| [ON] | Sets the backlight to always be ON. |
| [OFF] | Sets the backlight to always be OFF. |
| [MANUAL] | The backlight will turn ON/OFF when the light connected to the drive unit is turned ON/OFF. If no light is connected, the backlight can be turned ON/OFF by operating the cycle computer's light button. |

3. Press Assist-A or the function button to finalize the selected setting.

The display will automatically return to the setting menu.

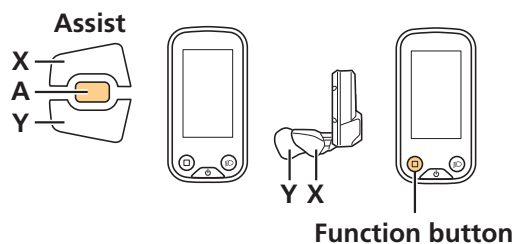

[Brightness]

Sets the display brightness.

1. Display the [Brightness] menu.

(1) Display the setting menu.

(2) Press Assist-X or Assist-Y, select [Brightness], and then press Assist-A or the function button.

2. Press Assist-X or Assist-Y to adjust the brightness of the display.

It can be set to one of five brightness levels.

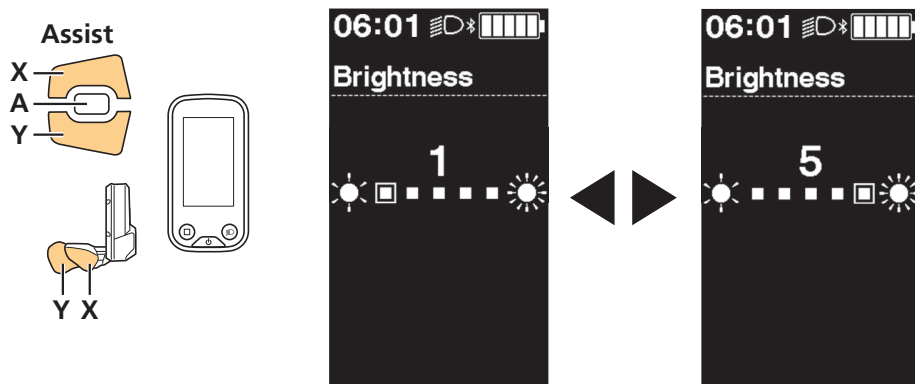

3. Press Assist-A or the function button to finalize the setting.

The display will automatically return to the setting menu.

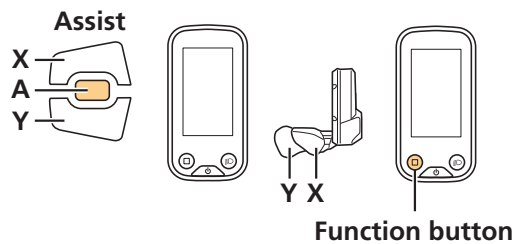

[Beep]

Turns the operation sound ON/OFF. Even if this is set to [OFF], a beep will sound when there is an incorrect operation, system malfunction, etc.

1. Display the [Beep] menu.

(1) Display the setting menu.

(2) Press Assist-X or Assist-Y, select [Beep], and then press Assist-A or the function button.

2. Press Assist-X or Assist-Y to select the item to set.

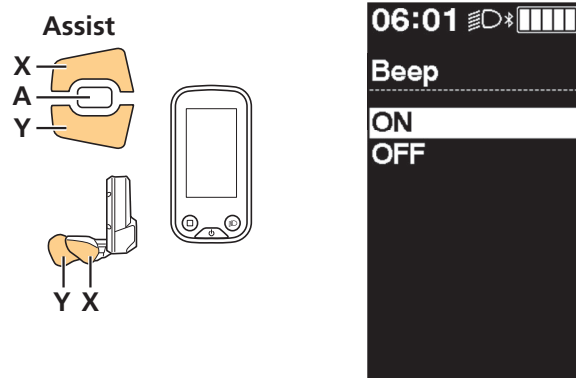

| Selectable items | Explanation |
|------------------|--------------------------------|
| [ON] | Turns the operation sound ON. |
| [OFF] | Turns the operation sound OFF. |

3. Press Assist-A or the function button to finalize the selected setting.

The display will automatically return to the setting menu.

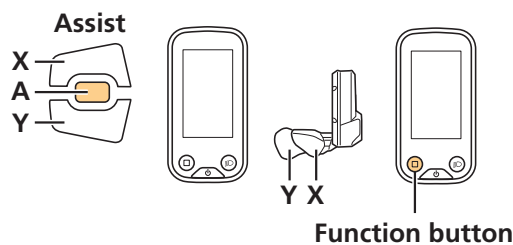

[Unit]

Switches the display unit between km and mile.

1. Display the [Unit] menu.

(1) Display the setting menu.

(2) Press Assist-X or Assist-Y, select [Unit], and then press Assist-A or the function button.

2. Press Assist-X or Assist-Y to select the item to set.

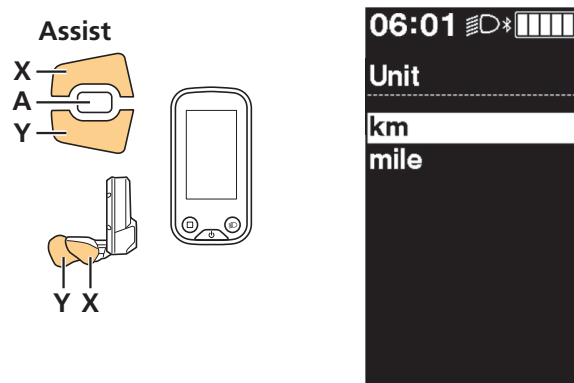

| Selectable items | Explanation |
|------------------|-------------------|
| [km] | Display in km. |
| [mile] | Display in miles. |

3. Press Assist-A or the function button to finalize the selected setting.

The display will automatically return to the setting menu.

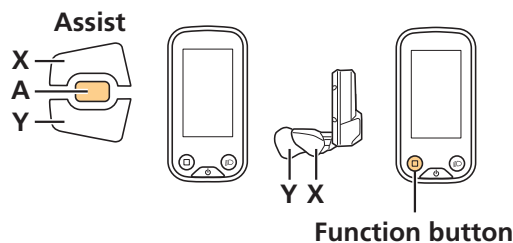

[Language]

Sets the display language.

1. Display the [Language] menu.

- (1) Display the setting menu.
- (2) Press Assist-X or Assist-Y, select [Language], and then press Assist-A or the function button.

2. Press Assist-X or Assist-Y to select the item to set.

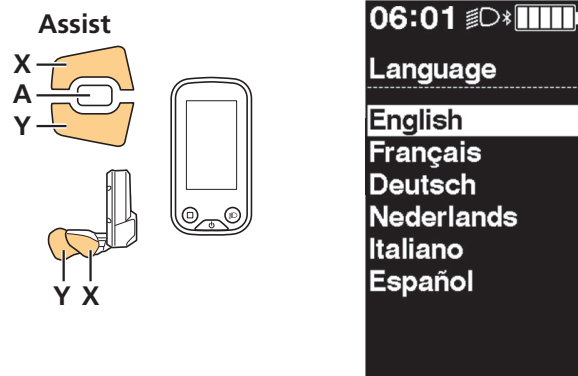

| Selectable items | Explanation |
|------------------|-------------|
| [English] | English |
| [Français] | French |
| [Deutsch] | German |
| [Nederlands] | Dutch |
| [Italiano] | Italian |
| [Español] | Spanish |

3. Press Assist-A or the function button to finalize the selected setting.

The display will automatically return to the setting menu.

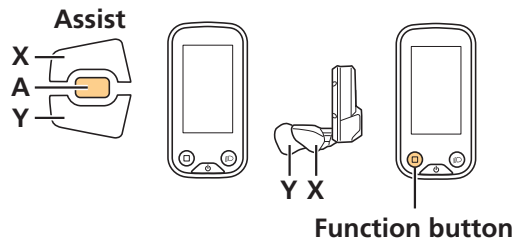

[Font color]

Switches the font color between black and white.

1. Display the [Font color] menu.

(1) Display the setting menu.

(2) Press Assist-X or Assist-Y, select [Font color], and then press Assist-A or the function button.

2. Press Assist-X or Assist-Y to select the item to set.

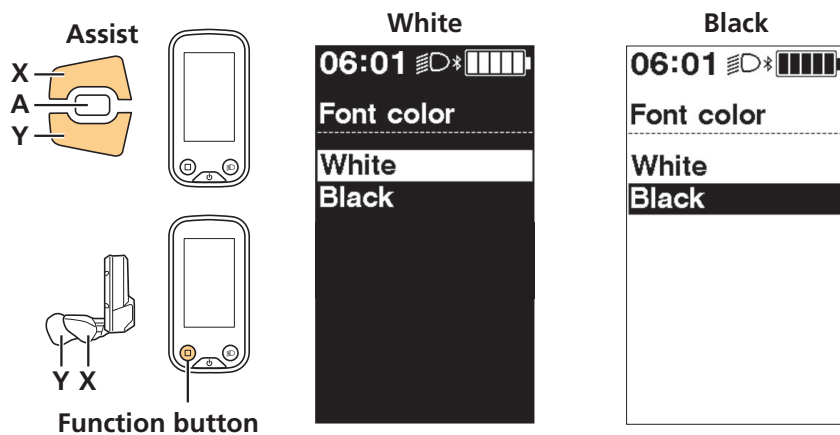

| Selectable items | Explanation |
|------------------|--|
| [White] | Displays white text on a black background. |
| [Black] | Displays black text on a white background. |

3. Press Assist-A or the function button to finalize the selected setting.

The display will automatically return to the setting menu.

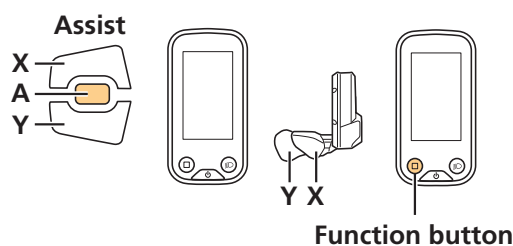

[Adjust]

Adjusts gear shifting for the electronic gear shifter.

⚠ CAUTION

- Improper adjustment may cause gear engagement skipping, resulting in an accidental fall.

NOTICE

- Mount the bicycle to a maintenance stand or otherwise secure it in place so that the rear wheel can be spun freely.
- Perform adjustment only when gear shifting feels unusual. Under normal conditions, performing unnecessary adjustment may worsen gear shifting performance.

TECH TIPS

- The adjustment range varies for rear derailleur (-16 to +16) and internal geared hub (motor unit) (-4 to +4). This section uses screens from a rear derailleur model for explanation.

▶ Checking the setting

First check whether the [Adjust] setting is [0].

1. Display the [Adjust] menu to check the current setting.

- (1) Display the setting menu.
- (2) Press Assist-X or Assist-Y, select [Adjust], and then press Assist-A or the function button.
- (3) Check the number in the center of the screen in the [Adjust] menu.
 - Number is [0]: Proceed to "Adjusting when the setting value is [0]."
 - Number is not [0]: Proceed to "Adjusting when the setting value is not [0]."

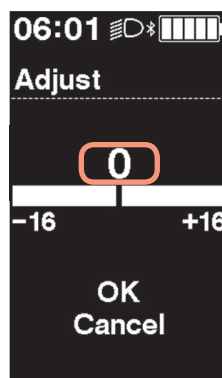

▶ Adjusting when the setting value is [0]

If the setting value is [0], adjust the setting value one step at a time with [0] as the reference value.

1. Press Assist-X or Assist-Y to adjust the setting value one step in the positive or negative direction.

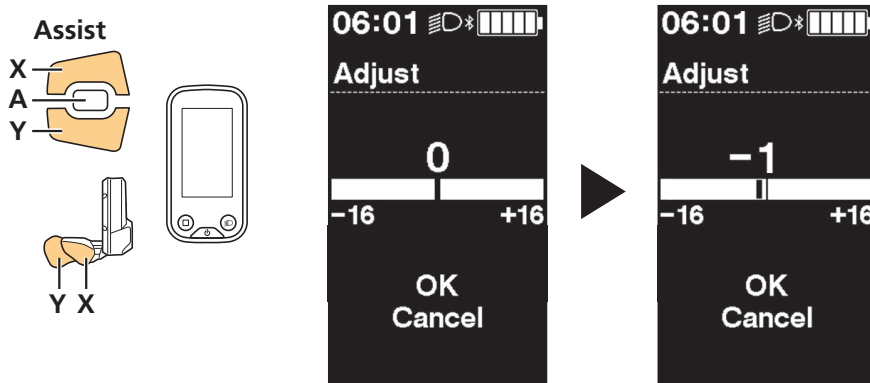

2. Press Shift-X or Shift-Y, select [OK], and then press Assist-A or the function button.

The adjusted value is set and the screen returns to the basic screen.

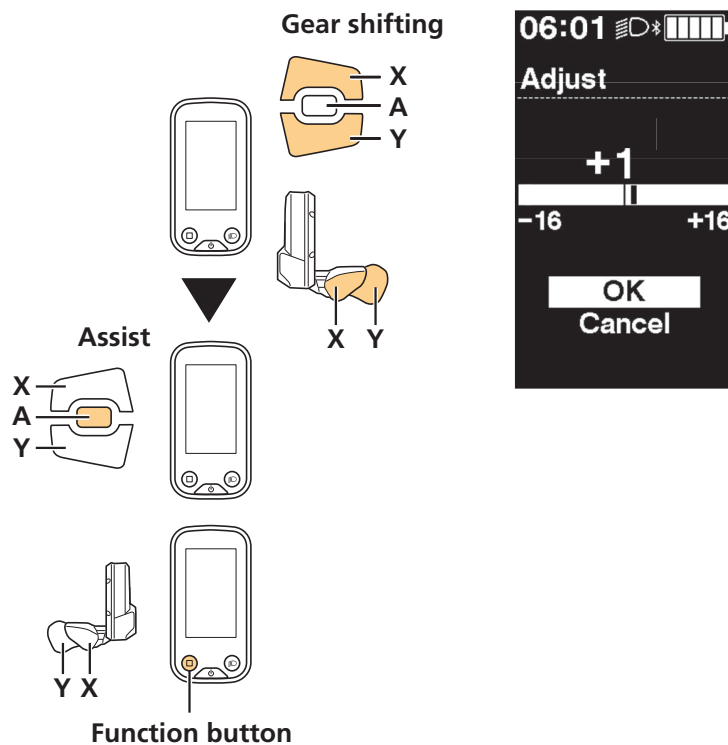

3. Press Shift-X and Shift-Y while turning the crank, and try shifting gears.

Check the symptom compared with the value prior to adjustment.

4. Proceed to adjust according to the symptom, as shown below.

Change the adjustment value according to the symptom, and repeat the following until the abnormal noise or unusual feel is resolved.

If the symptom is improved, or there is no noticeable change

- (1) Refer to "Checking the setting" and return to the [Adjust] menu.
- (2) Change the adjustment value another step in the same direction (positive or negative) as the change that was just made.
- (3) Return to the basic screen, and once again shift gears to check the symptom.

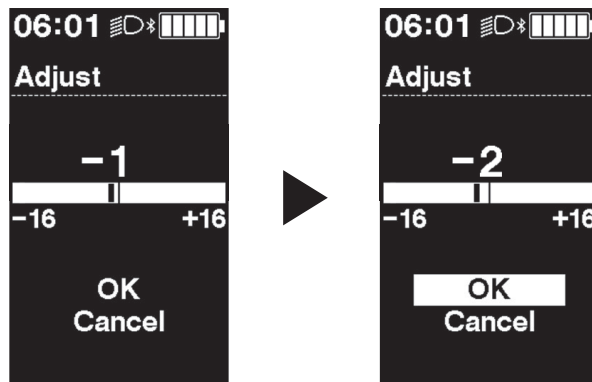

If the symptom is worse

- (1) Refer to "Checking the setting" and return to the [Adjust] menu.
- (2) Change the adjustment value two steps in the opposite direction (positive or negative) as the change that was just made.
- (3) Return to the basic screen, and once again shift gears to check the symptom.

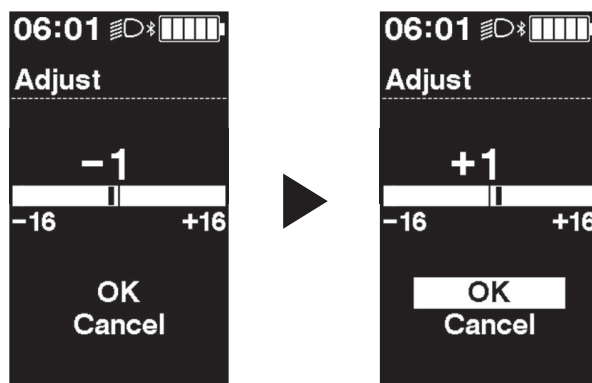

5. Finally, ride the bicycle and try shifting gears to check that the abnormal noise or unusual feel has been resolved.

▶ Adjusting when the setting value is not [0]

If the setting value is not [0], set the setting value to [0] prior to adjusting.

1. Press Assist-X or Assist-Y to set the number back to [0].

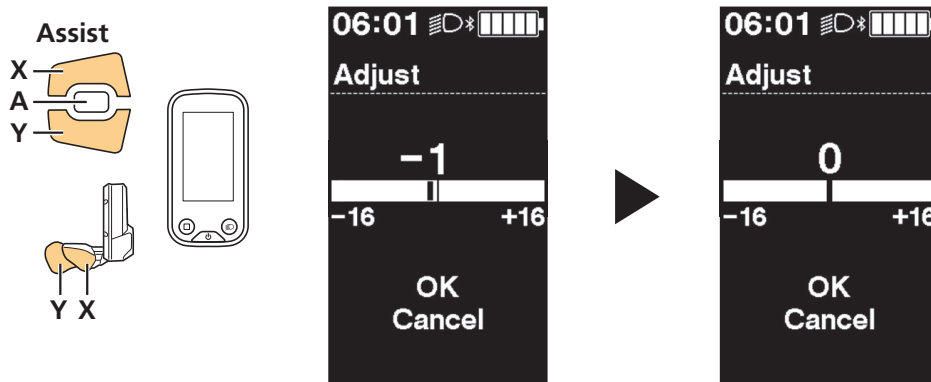

2. Press Shift-X or Shift-Y, select [OK], and then press Assist-A or the function button.

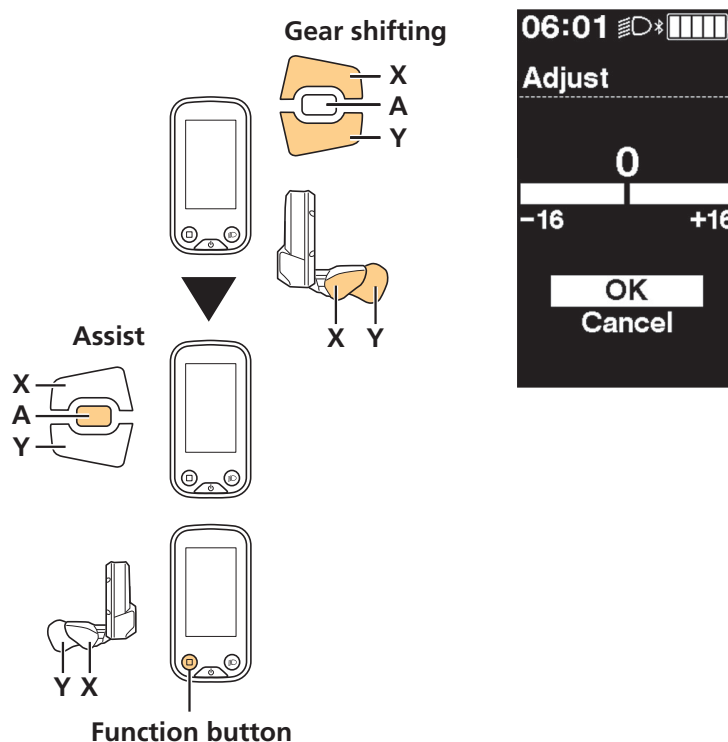

3. Press Shift-X and Shift-Y while turning the crank, and try shifting gears.

Check the symptom compared with the value prior to adjustment. Refer to step 4 in "Adjusting when the setting value is [0]" and adjust according to the symptom.

4. Finally, ride the bicycle and try shifting gears to check that the abnormal noise or unusual feel has been resolved.

[Shift timing]

Adjusts the gear shifting timing during automatic gear shifting. Also sets the timing at which gear shifting advice is displayed.

1. Display the [Shift timing] menu.

- (1) Display the setting menu.
- (2) Press Assist-X or Assist-Y, select [Shift timing], and then press Assist-A or the function button.

2. Press Assist-X or Assist-Y to adjust the number.

- Press Assist-X to increase the number. At larger numbers, gear shifting timing and manual gear shifting advice will be displayed at a lower pedal load. Pedaling will feel lighter to the rider.
- Press Assist-Y to decrease the number. At smaller numbers, gear shifting timing and manual gear shifting advice will be displayed at a higher pedal load. Pedaling will feel heavier to the rider.

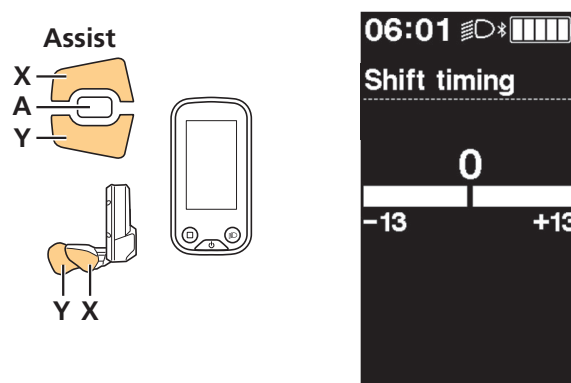

3. Press Assist-A or the function button to finalize the selected setting.

The display will automatically return to the setting menu.

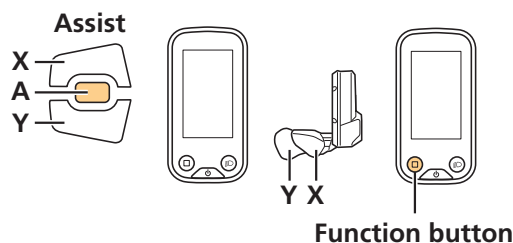

[Shifting advice]

Sets whether to display the recommended gear shifting timing on the cycle computer during manual gear shifting.

1. Display the [Shifting advice] menu.

- (1) Display the setting menu.
- (2) Press Assist-X or Assist-Y, select [Shifting advice], and then press Assist-A or the function button.

2. Press Assist-X or Assist-Y to select the item to set.

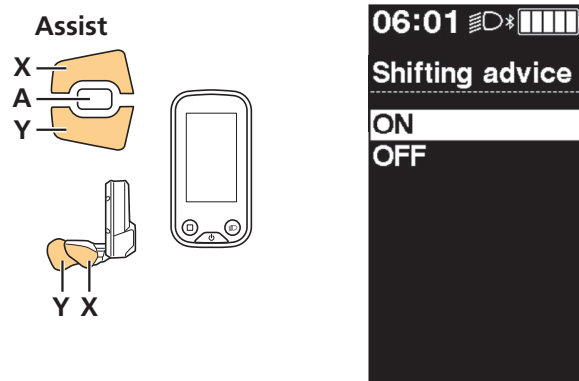

| Selectable items | Explanation |
|------------------|---|
| [ON] | Enables the gear shifting advice function, which displays an icon to notify the user of the recommended timing for gear shifting during manual gear shifting. |
| [OFF] | Disables the gear shifting advice function. |

3. Press Assist-A or the function button to finalize the selected setting.

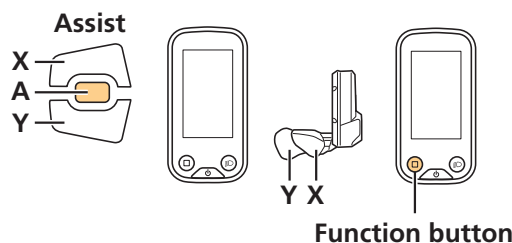

[RD protection reset]

In order to protect the system from falls etc., the RD Protection function will operate when the rear derailleur is subjected to a strong impact. The connection between the motor and the link will be momentarily severed so that the rear derailleur can no longer operate. When RD Protection Reset is run, it will restore the connection between the motor and the link, and recover the rear derailleur from RD protection.

NOTICE

- Mount the bicycle to a maintenance stand or otherwise secure it in place so that the rear wheel can be spun freely.

1. Display the [RD protection reset] menu.

(1) Display the setting menu.

(2) Press Assist-X or Assist-Y, select [RD protection reset], and then press Assist-A or the function button.

2. Press Assist-X or Assist-Y and select [OK].

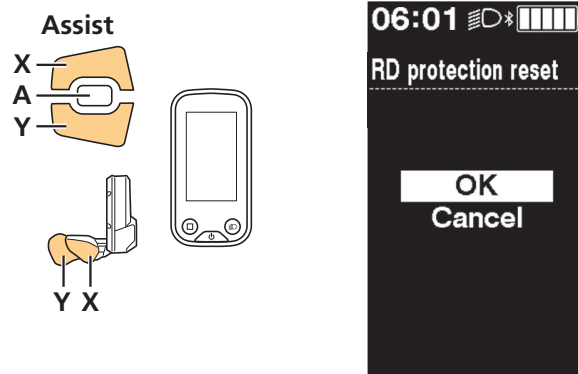

| Selectable items | Explanation |
|------------------|-------------------------------|
| [OK] | Performs RD Protection Reset. |
| [Cancel] | Returns to the setting menu. |

3. Press Assist-A or the function button.

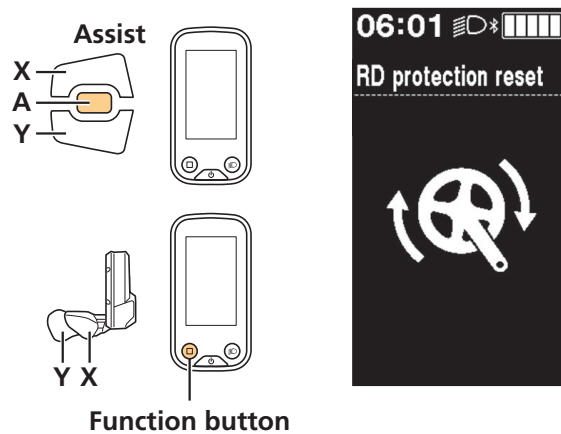

4. Turn the crank.

The rear derailleur moves, and the connection between the motor and link is restored.

[Exit]

Returns to the basic screen.

1. On the setting screen, press Assist-X or Assist-Y, select [Exit], and then press Assist-A or the function button.

Updating drive unit backup data

The cycle computer has a function to automatically back up drive unit settings. Settings can be recalled by connecting the cycle computer to E-TUBE PROJECT, even if the drive unit is malfunctioning.

Setting Mode (EW-EN100)

It is impossible to switch to the setting mode when riding the bicycle.

RD protection reset

In order to protect the system from falls etc., the RD Protection function will operate when the rear derailleur is subjected to a strong impact. The connection between the motor and the link will be momentarily severed so that the rear derailleur can no longer operate. When RD Protection Reset is run, it will restore the connection between the motor and the link, and recover the rear derailleur from RD protection.

NOTICE

- Mount the bicycle to a maintenance stand or otherwise secure it in place so that the rear wheel can be spun freely.
- This function is enabled for electronic gear shifting rear derailleur models only. If an electronic gear shifting rear derailleur is not connected, the system will not switch to the setting mode even if the operation described here is performed.

1. Hold the button down (for roughly eight seconds) until the LED (inward) flashes red.

Once the LED is flashing, release the button. When only the LED (inward) is flashing red, the system is in the RD Protection Reset mode.

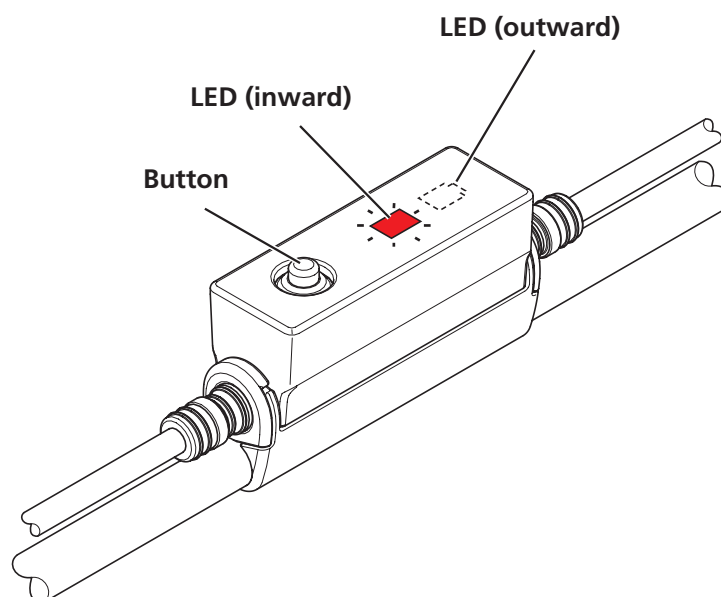

2. Turn the crank arm.

The rear derailleur moves, and the connection between the motor and link is restored.

Adjust

Adjust gear shifting for the electronic gear shifting rear derailleur.

- A switch unit configured as a shifting switch is required to set this.
- Gear shifting can be adjusted from E-TUBE PROJECT for electronic gear shifting (internal geared hub models). Refer to the help manual for E-TUBE PROJECT for details.

NOTICE

- Mount the bicycle to a maintenance stand or otherwise secure it in place so that the rear wheel can be spun freely.
- Perform adjustment only when gear shifting feels unusual. Under normal conditions, performing unnecessary adjustment may worsen gear shifting performance.

1. Turn the main power ON.

2. Shift the rear derailleur to the fifth gear position from the largest sprocket.

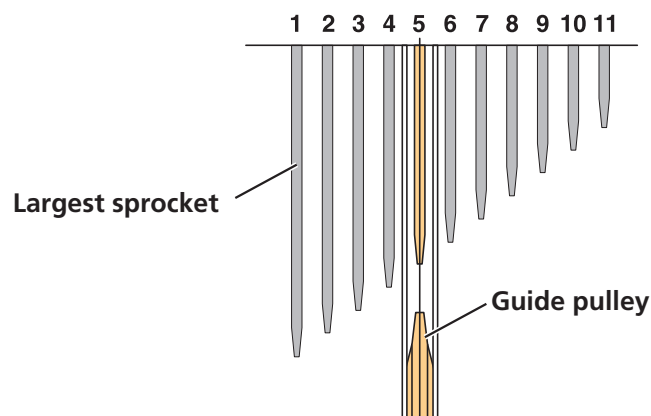

3. Hold the button down (for roughly five seconds) until the LED (inward) lights up red.

Once the LED (inward) lights up, release the button. When only the LED (inward) is lit up red, the system is in the Adjust mode.

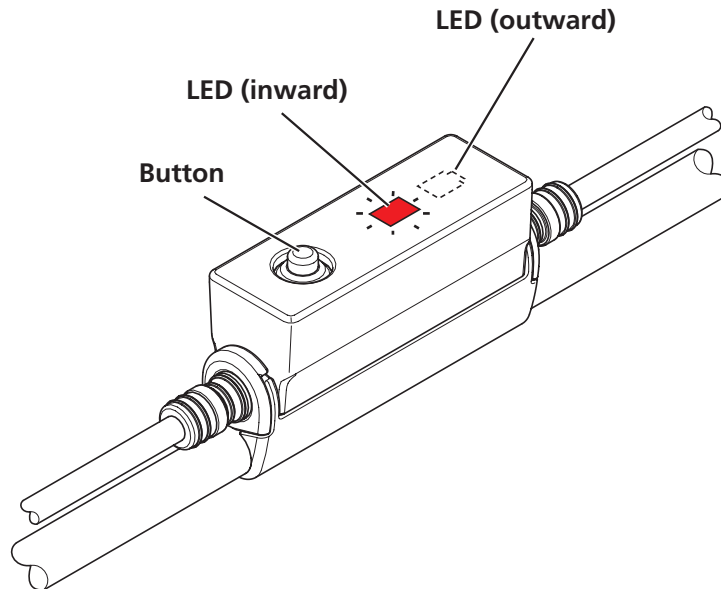

NOTICE

- Note that if you keep pressing the button after the LED (inward) lights up red, RD Protection Reset will start.

4. Press Shift-Y while turning the crank, and move the guide pulley toward the largest sprocket.

Move it to the position where the chain makes contact with the fourth gear and a subtle noise is heard.

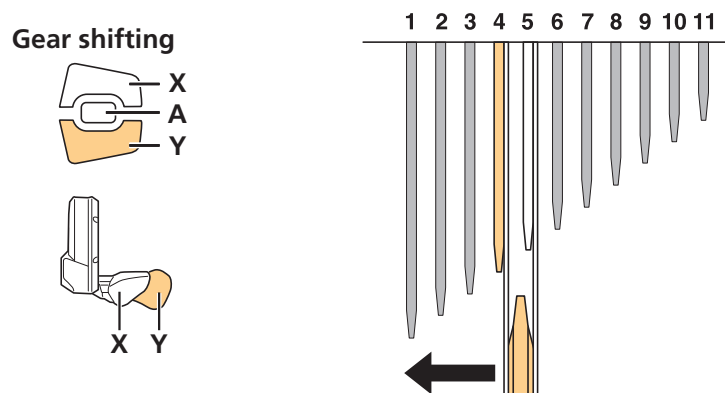

TECH TIPS

- The guide pulley can move 16 steps inward and 16 steps outward from the initial position, for a total of 33 positions.

5. Press Shift-X five times to move the guide pulley five steps toward the smallest sprocket.

This position will serve as the target for adjustment.

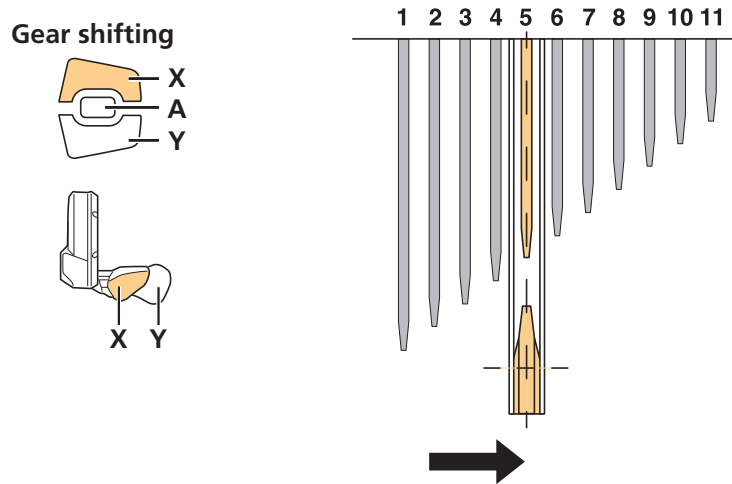

6. Press the EW-EN100 button.

The adjustment change is finalized and the system exits adjust mode.

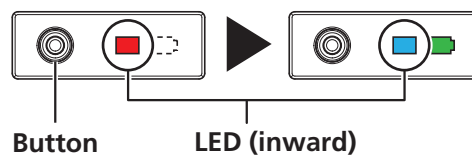





7. Press Shift-X and Shift-Y while turning the crank, and try shifting gears.

If fine adjustment is required, return to step 3 and repeat adjusting the rear derailleur.

Battery LED Error Indications

The battery LEDs are used to notify the user of system malfunctions, etc.

| Error indication type | Indication condition | LED indication*1 | Remedies |
|-------------------------------|--|--|---|
| System malfunction | Communication error with the bicycle system |  | Check that the electric wire is not loose, and that it is appropriately connected. If the situation is not improved, contact a distributor. |
| Temperature protection | If the temperature exceeds the guaranteed operating range, the battery output is turned off. |  | Leave the battery in a cool place away from direct sunlight until the internal temperature of the battery decreases sufficiently. If the situation is not improved, contact a distributor. |
| Security authentication error | <ul style="list-style-type: none"> Genuine drive unit not connected Cable disconnected |  | Connect a genuine drive unit and battery. Check the status of the electric wire. If the situation is not improved, contact a distributor. |
| Charge error | An error occurred during charging |  | Detach the connector between the battery and battery, and press the power switch with only the battery connected. If an error appears with only the battery connected, contact a distributor. |
| Battery malfunction | Electrical failure inside the battery |  | Temporarily connect the battery charger to the battery, remove it, and then press the power switch with only the battery connected. If an error appears with only the battery connected, contact a distributor. |

*1 ● Off ● Lit  Flashing

Cycle Computer Error Messages

Warnings

If the situation is resolved, this indication will disappear. If the situation does not improve, consult an agency.



| Cable | Indication condition | Operational restrictions being displayed | Remedy |
|-------|--|---|---|
| W011 | The traveling speed cannot be detected. | The maximum speed up to which assist is provided will be lower than normal. | Check that the speed sensor is properly installed. |
| W013 | Initialization did not complete normally for the torque sensor. | Assistance will be lower than normal. | Press the battery power button without stepping on the pedal to turn on the power again. |
| W032 | The installed derailleur differs from the derailleur configured in the system. | Unable to perform gear shifting. | Switch the installed derailleur for a derailleur that is configured in the system. Or, confirm the current system status on E-TUBE PROJECT. |

Errors

If an error message is displayed on the entire screen, follow one of the procedures below to reset the display.

- Press the battery power switch to turn the power OFF.
- Remove the battery from the mount.

If the situation does not improve even after turning the power back ON, consult with a distributor.



| Cable | Indication condition | Operational restrictions being displayed | Remedy |
|-------|--|--|--|
| E010 | A system error was detected. | Assist will not be provided when riding. | Use the battery power button to turn the power OFF, and then turn the power back ON. |
| E013 | An error was detected in the drive unit's firmware. | Assist will not be provided when riding. | Consult with a distributor. |
| E014 | The speed sensor may be installed in the wrong position. | Assist will not be provided when riding. | Use the battery power button to turn the power OFF, and then turn the power back ON. |
| E020 | A communication error between the battery and drive unit was detected. | Assist will not be provided when riding. | Use the battery power button to turn the power OFF, and then turn the power back ON. |
| E021 | The battery connected to the drive unit is compliant with system standards, but is not compatible. | Assist will not be provided when riding. | Use the battery power button to turn the power OFF, and then turn the power back ON. |

| | | | |
|------|---|--|--|
| E022 | The battery connected to the drive unit is not compliant with system standards. | Assist will not be provided when riding. | Use the battery power button to turn the power OFF, and then turn the power back ON. |
| E030 | The installed derailleur differs from the derailleur configured in the system. | Assist will not be provided when riding. | Connect to E-TUBE PROJECT and update to the correct settings. |
| E033 | The current firmware is not compatible with this system. | Assist will not be provided when riding. | Connect to E-TUBE PROJECT and update all units for the assist bicycle to their latest firmware versions. |
| E043 | The cycle computer's firmware may be partially corrupt. | Assist will not be provided when riding. | Consult with a distributor. |

Maintenance alert

This notifies the user that the bicycle requires maintenance. An icon is displayed on the cycle computer screen when the bicycle reaches the set odometer or date. You must connect to E-TUBE PROJECT for this setting. Refer to the help manual for E-TUBE PROJECT for details.



EW-EN100 Error Indication

When an error occurs, the two LEDs on EW-EN100 will quickly flash red at the same time.

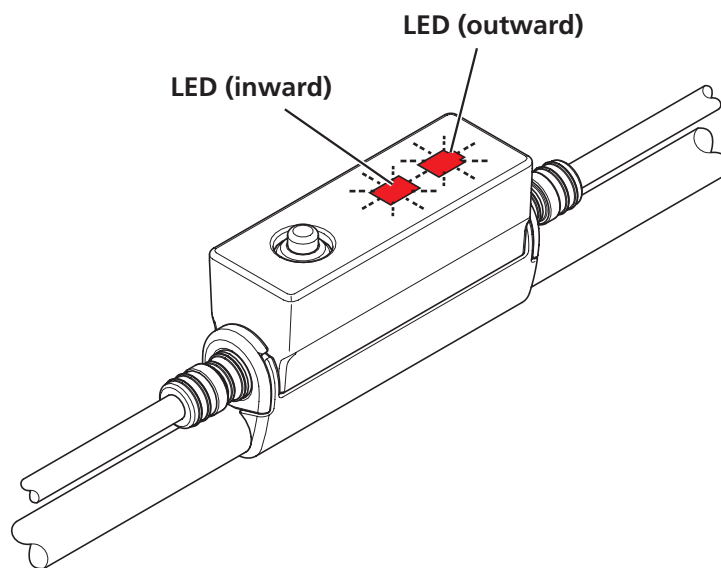

If this occurs, follow one of the procedures below to reset the indication.

- Press the battery power switch to turn the power OFF.
- Remove the battery from the mount.

If the situation does not improve even after turning the power back ON, consult with a distributor.

CONNECTION AND COMMUNICATION WITH DEVICES

E-TUBE PROJECT

Connecting the bicycle to a device allows you to configure the system, update firmware, and more.

E-TUBE PROJECT is needed to change the setting of the SHIMANO STEPS and to update firmware.

Download E-TUBE PROJECT from our support website (<http://e-tubeproject.shimano.com>).

For information on how to install E-TUBE PROJECT, check the support website.

TECH TIPS

- SM-PCE1 is needed to connect SHIMANO STEPS to a PC. SM-JC40/JC41 will be needed in the following situations.
 - There are no free E-TUBE ports on the cycle computer (for example, if using electronic gear shifting)
 - If connecting the switch unit by itself to the PC
- Firmware is subject to change without notice.
- PC connection and communication are not possible when charging the battery. Do not connect to a device while the battery is being charged.

Drive unit setting backup function

To check the drive unit settings backed up to the cycle computer, export a PDF report from the E-TUBE PROJECT [Unit log acquisition] menu. When exchanging the drive unit, send the report along with the drive unit to the distributor from which the unit was purchased.

Wireless Function

SHIMANO STEPS cycle computers and junction (A) are both able to communicate wirelessly.

Functions

You can check the latest functions by using E-TUBE PROJECT to update the software.

▶ ANT connection

The wireless unit can send all information displayed on the basic screen of the cycle computer to an external device.

▶ Bluetooth® LE connection

E-TUBE PROJECT for smartphones/tablets may be used if a Bluetooth LE connection is established with a smartphone/tablet. A special connectivity app can be used to check traveling data on a smartphone connected over Bluetooth LE, even when using EW-EN100.

Connection method

To connect an external device wirelessly to SC-E6100 or EW-EN100, the device needs to be in connection mode. For information on how to set external devices in connection mode, refer to the user's manual for the external device.

▶ ANT connection

When the main power is turned ON for SHIMANO STEPS, communication can be received at any time. Switch the external device to connection mode and then connect it.

▶ Bluetooth® LE connection

Communication can only be received under the following conditions. Switch the external device to connection mode in advance.

- Within 15 seconds of the main power for SHIMANO STEPS turning ON
- Within 15 seconds of operating any button other than the SHIMANO STEPS power switch

▶ 2.4 Ghz digital wireless systems

2.4 GHz frequency digital wireless technology is the same thing as a wireless LAN. In rare instances, strong electromagnetic waves or electromagnetic interference due to the following locations or devices may impact communication.

- TVs, PCs, radios, motors/engines, or inside vehicles or trains
- Near railroad crossings and tracks, television transmitter stations, and radar stations
- Other wireless computers or digital control lights

Items Configurable in E-TUBE PROJECT

Refer to the help manual for E-TUBE PROJECT for details.

| | | |
|--------------------------------|-----------------------------------|--|
| Switch function setting | | Assigns functions to each operation switch on the switch unit. |
| Drive unit settings | Light connection | Set whether a light is connected to the drive unit. |
| | Start mode *1 | Turns the start mode ON/OFF. The gear position when starting off from a stop can be set when ON is selected. |
| | Automatic gear shifting *1 | Enables/disables automatic gear shifting. |
| | Gear shifting timing *2 | Adjusts the gear shifting timing during automatic gear shifting. Also sets the timing at which gear shifting advice is displayed. |
| | Gear shifting advice*3 | Sets whether to display the recommended gear shifting timing on the cycle computer during manual gear shifting. |
| | Riding characteristics | Select the output characteristics of the drive unit. |
| | Maximum assist speed | Assist is provided up to the set speed. The maximum assist speed is determined by law, depending on the country of use. |
| | Maintenance alert | Notifies the user when maintenance is required by displaying an icon on the cycle computer when the set odometer or date is reached. |

| | | |
|---|--|---|
| Display settings (SC-E6100) | Display units | Switches between displaying km or miles. |
| | Time setting | Sets the time displayed on the cycle computer. |
| | Backlight setting | Turns the display backlight ON/OFF. |
| | Backlight brightness setting | Sets the display brightness. |
| | Beep setting | Turns the operation sound ON/OFF. |
| | Display language | Sets the display language. |
| | Font color setting | Switches the font color between black and white. |
| | Traveling data display | Sets whether to display each item (traveling time, average speed, maximum speed, cadence (crank rotation speed), and maximum traveling distance) on the cycle computer. |
| Derailleur adjustment setting *1 | Adjusts the connected motor unit. There is normally no need to change this. | |
| Motor unit gear count setting *1 | Sets the number of gears the internal geared hub connected to the motor unit can be shifted. | |
| Multi shift mode setting *4 | When a switch unit is used as a shifting switch, this sets the maximum number of gears that can be shifted by holding the switch down. | |
| Other functions | <ul style="list-style-type: none"> • Error log • Update firmware • Preset • Unit log acquisition | |

*1 Electronic gear shifting/internal geared hub models only.

*2 Only for electronic gear shifting.

*3 Only for electronic gear shifting with the gear shifting mode set to [Manual].

*4 Electronic gear shifting rear derailleur models only.

Connecting to a PC

Connect the PC to SHIMANO STEPS. You can either connect a single SHIMANO STEPS component unit, or connect all SHIMANO STEPS components installed on the bicycle at the same time.

Connection with single unit

1. Connect the unit's E-TUBE port and the PC over the PC linkage device.

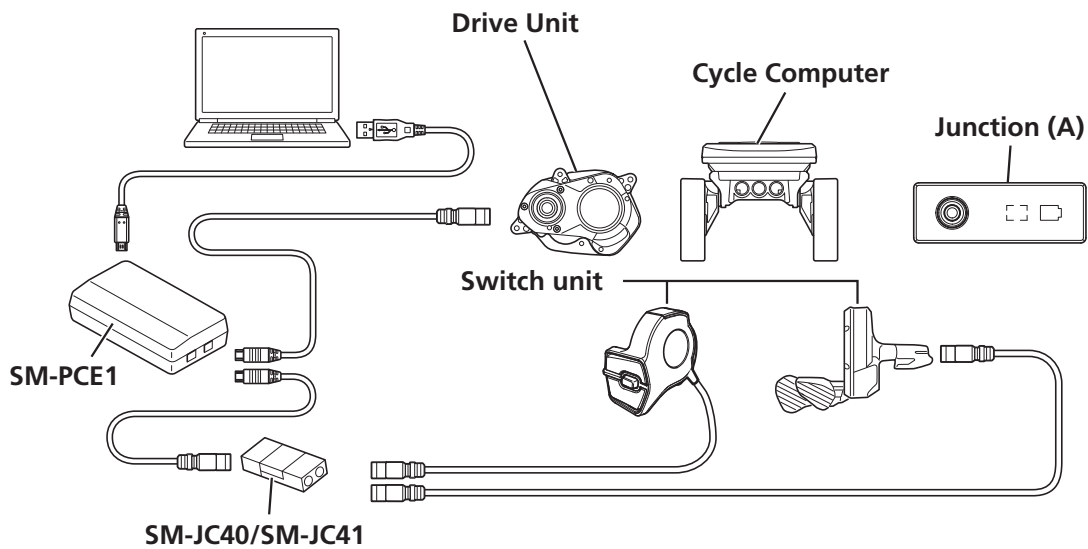

NOTICE

- SM-JC40 or SM-JC41 is required to connect a single switch unit to a PC.

Connection with all SHIMANO STEPS components

To connect all SHIMANO STEPS components installed to the bicycle, connect the cycle computer or junction (A) to the PC. If there are no free E-TUBE ports, use either SM-JC40 or SM-JC41.

▶ SC-E6100 (with free port)

Connect as follows for configurations using mechanical gear shifting with a free E-TUBE port on SC-E6100.

1. Connect a free port on the cycle computer to the PC linkage device.

- (1) Remove the dummy plug from a free port on the cycle computer.
- (2) Connect the free port on the cycle computer and the PC linkage device.

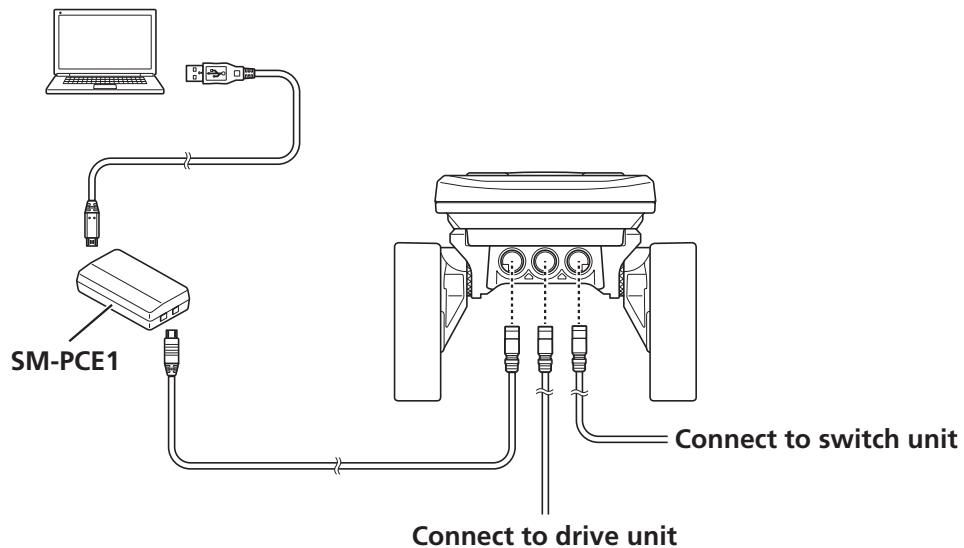

▶ SC-E6100 (without free port)

Connect as follows for configurations using electronic gear shifting without a free E-TUBE port on SC-E6100.

1. Reconnect the wires from SC-E6100 to the PC as follows.

- (1) Connect SM-JC40/SM-JC41 to the PC linkage device.
- (2) Disconnect the electric wire connected to the drive unit from the center port of the cycle computer, and connect it to SM-JC40/SM-JC41.
- (3) Connect the center port of the cycle computer and SM-JC40/SM-JC41 with an electric wire.

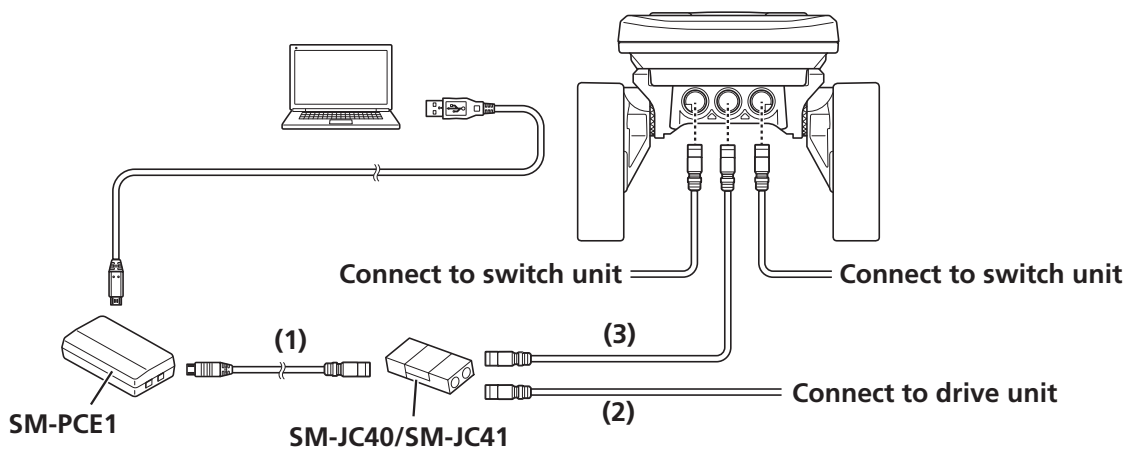

▶ EW-EN100 (with free port)

Connect as follows if EW-EN100 is not connected to anything other than a drive unit.

1. Connect the PC linkage device to a free port on EW-EN100.

- (1) Remove the dummy plug from a free port on EW-EN100.
- (2) Connect the free port on EW-EN100 with the PC linkage device.

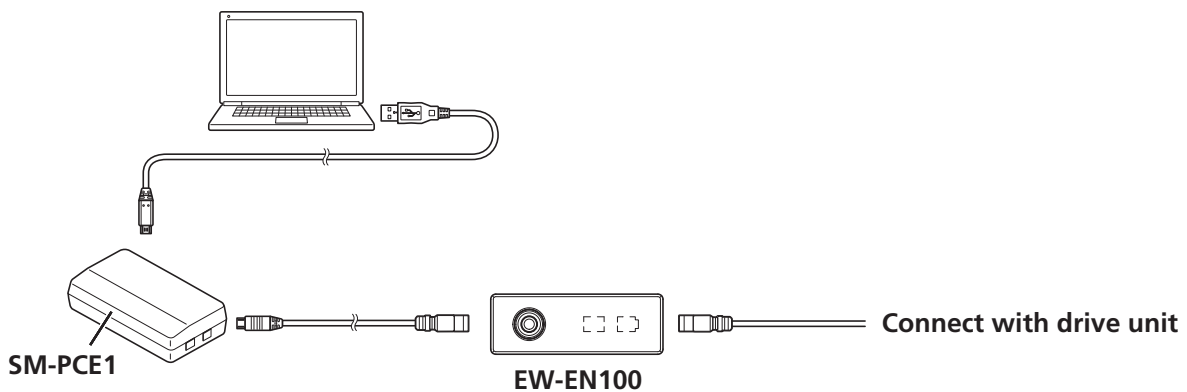

▶ EW-EN100 (without free port)

Connect as follows if a switch unit is connected and there are no free E-TUBE ports on EW-EN100.

1. Reconnect the wires from EW-EN100 to the PC as follows.

- (1) Connect SM-JC40/SM-JC41 to the PC linkage device.
- (2) Disconnect the electric wire connected to the drive unit from EW-EN100, and connect it to SM-JC40/SM-JC41.
- (3) Connect a free port on EW-EN100 and SM-JC40/SM-JC41 using an electric wire.

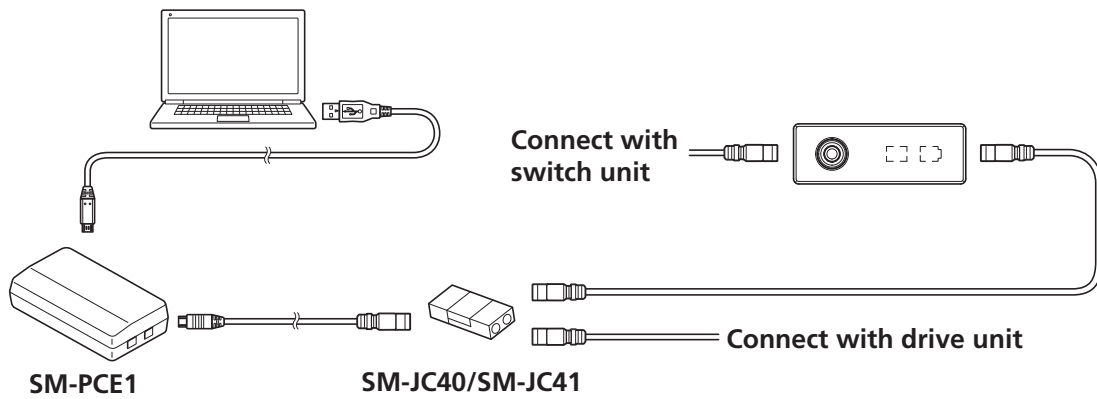

MAINTENANCE

Replacing the front chainring

When replacing the front chainring, make sure that the chain is attached.

Refer to the "Installing the Front Chainring and Crank Arms" and "Installing the Arm Covers" sections for detailed instructions.

1. Remove the left and right crank arms.
2. Remove the arm cover if it is attached.
3. Remove the lock ring (left screw).

Remove the lock ring, with the rear wheel held firmly so that it does not move.

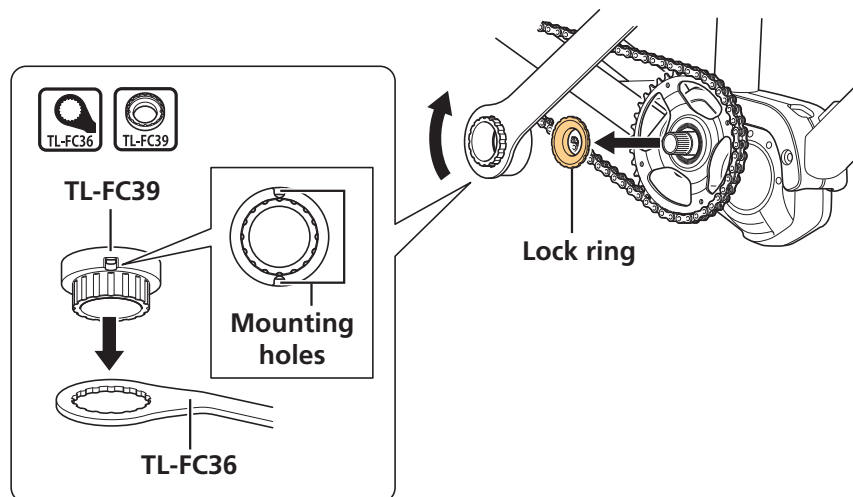

4. Replace the front chainring.

Remove front chainring, and then install a new front chainring.

Replacing the chain guard

To remove the chain guard, first remove the chainring from the bicycle.

Refer to the previous section, "Replacing the front chainring" for information on how to remove the chainring.

1. Remove the chainring.
2. Remove the chain guard and then replace it with a new chain guard.

The figure below shows a double chain guard. The procedure is the same for replacing a single chain guard.

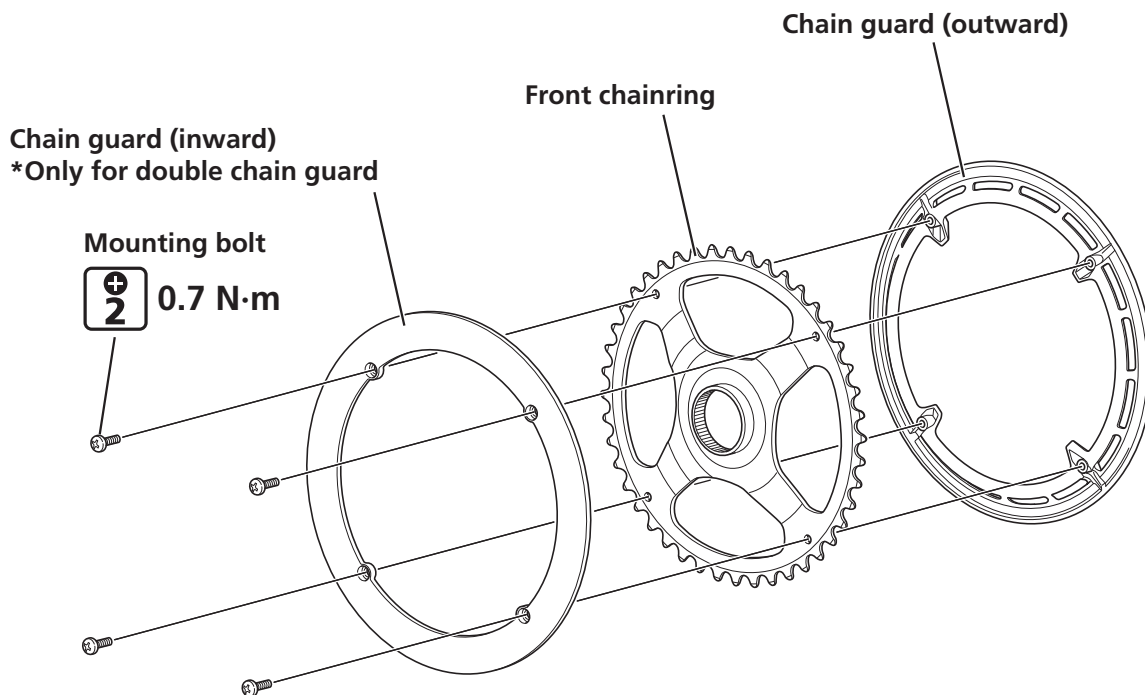

Replacing the Arm Cover

The arm cover can be replaced with the chainring attached to the drive unit. Refer to "Installing the Arm Covers" in "INSTALLING THE DRIVE UNIT AND PERIPHERAL PARTS."

SHIMANO

SHIMANO NORTH AMERICA BICYCLE, INC.

One Holland, Irvine, California 92618, U.S.A. Phone: +1-949-951-5003

SHIMANO EUROPE B.V.

High Tech Campus 92, 5656 AG Eindhoven, The Netherlands Phone: +31-402-612222

SHIMANO INC.

3-77 Oimatsu-cho, Sakai-ku, Sakai-shi, Osaka 590-8577, Japan

Please note: specifications are subject to change for improvement without notice. (English)

© Jun. 2018 by SHIMANO INC. ITP